

KUST Elektronik GmbH

LM1050

OPERATION MANUAL



KUST Elektronik GmbH

Am Weinberg 2

D-35619 Braunfels

Germany

E: info@kust-elektronik.com

P: +49 (0) 64414471223

Announcement

The description of the manual may not cover all contents of the instrument, and is subject to change and to improve the performance, function, inner structure, appearance, accessory and package of the instrument without notice. If there is a problem caused by inconsistency of manual and instrument, please contact our company.

1 Chapter 1 Out of Box Audit

When you receive the instrument, some inspections are necessary, and the condition must be understood and available before installing the instrument.

1.1 1.1 To Inspect the package

Inspect the shipping box for damage after unpacking it. It is not recommended to power on the instrument in the case of a damaged box.

If the contents in the container do not conform to the packing list, notify us or your dealer.

1.2 1.2 Power connection

- 1) Power-supplying voltage range: 100~120Vac or 198~242Vac. Being related with the power setup on the rear panel.
- 2) Power-supplying frequency range: 47~63Hz.
- 3) Power-supplying power range: less than 80VA.
- 4) Power supplying input phase line L, zero line N, ground lead E should be as same as the power plug of the instrument.
- 5) After careful design, the instrument can reduce the clutter jamming caused by AC power terminal input, however, it should be used under the environment with low-noise. Please install power filter if being unavoidable.

Warning: In order to prevent user and instrument from being hurt by leakage, it is necessary for user to guarantee the ground line of supply power being reliably grounded.

1.3 1.3 Fuse

The instrument has installed fuse, so operators should use the installed fuse of our company.

Warning: Be sure that the location of fuse is consistent with power-supplying voltage range before charging.

1.4 1.4 Environment

- 1) Please do not operate the instrument in the place that is: dusty, under direct sunlight or where there is corrosive environment.
- 2) The normal working temperature is $0^{\circ} \sim 40^{\circ}$, relative humidity $\leq 75\%$, so the instrument should be used under above condition to guarantee the accuracy.
- 3) There is heat abstractor on the rear panel to avoid the inner temperature rising. In order to keep good airiness, please don't obstruct the left and right airiness holes to make the instrument maintain the accuracy.
- 4) Although the instrument has been specially designed for reducing the noise caused by ac power, a place with low noise is still recommended. If this cannot be arranged, please make sure to use power filter for the instrument.
- 5) Please store the instrument in the place where temperature is between 5° C and 40° C , humidity is less than 85%RH. If the instrument will not be put in use for a time, please have it properly packed with its original box or a similar box for storing.
- 6) The instrument/test cable should be far from strong electro-magnetic field,

1.5 1.5 Use of Test Fixture

Please use the accessory test fixture or cable, **the test fixture made by user or from other company may cause the incorrect measurement result**. The test fixture or cable should be kept clean, as well as the pin of DUT, thus to guarantee the good connection between DUT and fixture. Connect the fixture or cable to four test terminals Hcur, Hpot, Lcur, Lpot on the front panel. As for the DUT with shielding shell, connect shielding layer or ground "⊥".

Note: When test fixture or cable has not being installed, the instrument will display an unstable test result.

1.6 1.6 Warm-up

- 1) To guarantee the accurate measurement, the warm-up time is no less than 15min.
- 2) Please not turn on or off instrument frequently, in order to avoid the inner data fluster.

1.7 1.7 Other features

- 1) Power: consumption power $\leq 80\text{VA}$.
- 2) Dimension (W*H*D): 398mm*129mm*370mm
- 3) Weight: About 9kg.

2 Chapter 2 Introduction

In this chapter, the basic operation features of LM1050 series are described. Please read the content carefully before using LM1050 series instruments, thus you can learn the operation of LM1050.

2.1 2.1 Introduction to front panel

Figure 2-1 shows the front panel LM1050.

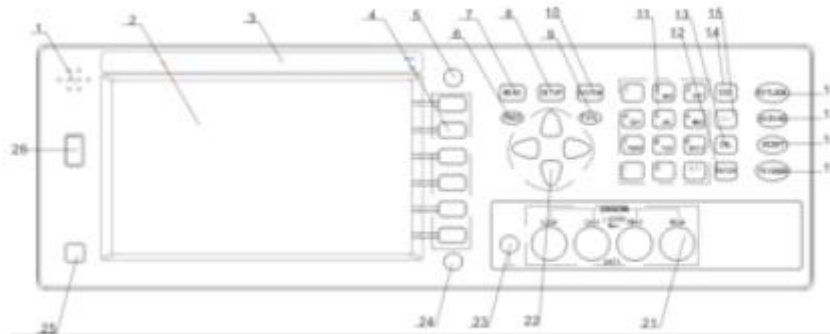

- 1) Buzzer window
- 2) LCD
800*480 colorful TFT LCD displays measurement results and conditions.
- 3) Brand and model
Brand and model
- 4) Soft keys
Six soft keys are used to select parameters. The corresponding function of each soft key has been displayed on its left (the right part of LCD). The function definition varies with different pages.
- 5) [FILE]
Press this key to enter into the file setup page.
- 6) PASS indicator
LED indicator shows the test result has passed.
- 7) [DISP]
Press this key to enter into the display page of transformer scanning test.
- 8) [SETUP]
Press this key to enter into the setup page of transformer scanning test.
- 9) FAIL indicator
LED indicator shows the test result has failed.
- 10) [SYSTEM]
Press this key to enter into the system setup page.
- 11) Numerical keys
These keys are used to input data to the instrument. The key consists of numerical keys [0] to [9], decimal point [.] and [+/-] key.
- 12) [ENTER]
This key is used to end the input of data, and confirm and save the data displayed on the inputting line (the bottom line on LCD).
- 13) [CAL]
Execute the calibration operation. Press this key to execute OPEN/SHORT calibration.

- 14) [ESC]
ESCAPE key
- 15) [←]
BACKSPACE key is used delete the last numeric of the input value.
- 16) [KEYLOCK]
Press [KEYLOCK], it will be lighted, which means the function of current panel is locked. Press it again, it will be off, which means discharging the lock status. If the password function is ON, it means correct password is necessary when discharging the key-lock, or the key cannot be unlocked.
- 17) [DC BIAS]
[DC BIAS] is used to permit or forbid the output of 0-100mA/10V DC bias source. Press this key, it will be lighted which means DC bias output is permitted. Press this key once more, it will be off which means DC bias output is prohibited. The key is useless in some pages where the DC BIAS cannot be added.
- 18) [RESET]
Press this key, when transformer auto scanning is cancelled, other operation cannot be executed on other pages.
- 19) [TRIGGER]
When the trigger mode is set to MAN mode, press this key to trigger the instrument.
- 20) Reserved.
- 21) Test terminals (UNKNOWN)
4-terminal test pair are used to connect 4-terminal test fixture or cable to measure DUT.
The 4 terminals are respectively as follows: Hcur, Hpot, Lpot and Lcur.
- 22) CURSOR
Cursor key is used to select cursor between zone and zone on LCD display page. When cursor moves to some zone, the zone displays with reverse on LCD.
- 23) Ground terminal
The ground terminal is connected with the case of instrument, which can be used to protect or shield the ground connection.
- 24) [COPY]
Copy the currently displayed page to USB memory.
- 25) POWER
Power switch
- 26) USB HOST interface
Connect U flash disk so as to save or use a specified file

2.2 Introduction to rear panel

Figure 2-2 shows the rear panel of LM1050.

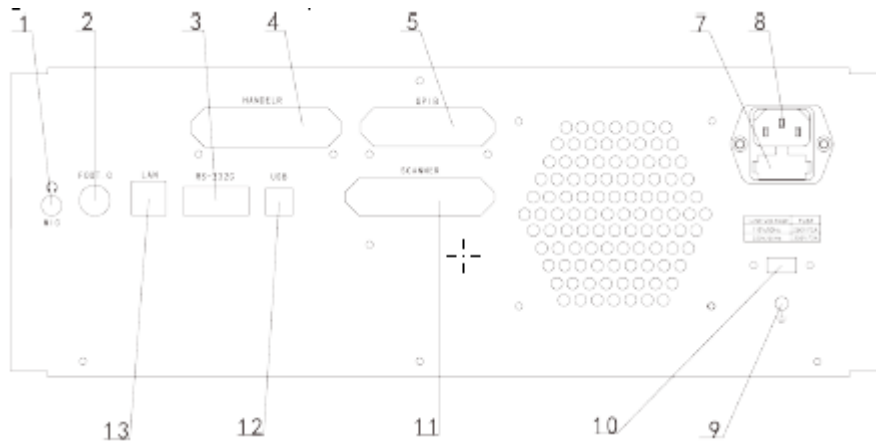

Figure 2-2 Rear panel

- 1) PHONE interface
- 2) FOOT. C: Used to connect footswitch.
- 3) RS232 interface
Series communication interface can realize the communication with PC.
- 4) HANDLER interface
Handler interface is used to realize the sorting output of test results.
- 5) IEEE-488 interface
The tester can communicate with PC through GPIB interface.
- 6) Fan window
Heat elimination, maintaining the normal working temperature
- 7) Fuse base
Being used to install power fuse, protect instrument.
- 8) Power socket
Input AC power.
- 9) Ground terminal
The ground terminal is connected with the case of instrument, which can be used to protect or shield the ground connection.
- 10) 110V/220V Switch
switch 110V/220V by changing the direction of core.

Warning: Be sure that the direction of fuse is accordant with power-supply voltage range before charging.

- 11) SCANNER interface
Control the transformer scanning box through SCANNER interface.
- 12) USB DEVICE interface
The tester can communicate with PC through the USB DEVICE interface.
- 13) LAN interface
LAN interface is used to realize the control and the communication of network system.

2.3 2.3 Basic Operation

Basic operation of LM1050 is as follows:

- Use menu keys ([DISP], SETUP, [SYSTEM]) and soft keys to select the desired page.
- Use cursor keys ([←][→]) and the slide switch to move the cursor to the desired zone. When the cursor moves to a specified zone, the zone will become reverse expression.
- The soft key functions corresponding to the current zone of the cursor will be displayed in the soft key zone. Users can select and use the desired key. Numeric keys, [BACKSPACE] and [ENTER] are used to input data. When a numeric key is pressed down, the usable unit soft key will be displayed in the soft key zone. You can choose a unit soft key or press [ENTER] to end data inputting. When [ENTER] is used to terminate data inputting, the unit of data will be set to a default unit, such as Hz, V or A. For example, the default unit for frequency is Hz.

2.4 2.4 Start the instrument

Plug in 3-line power plug.

Caution: Keep the power-supply voltage and frequency conform to above specifications. Power input phase line L, zero line N, ground line E should be the same as that of the instrument.

Press the power switch at the left corner on the front panel and then a boot screen will appear which displays our company logo, instrument model (LM1050), and the version number of the software (Ver1.0.X).

If the password protection function is on, users are required to input the password and then press [ENTER] to enter into the page of main menu.

Note: The instrument has a **default password 2876**. In your practical use, you can change it and set your own one. Please see <SYSTEM> section for more information.

3 Chapter 3 Introduction to [DISP]

3.1 3.1 <MEAS DISPLAY>

When the LCR function is applied, press [DISP], the <MEAS DISPLAY> page will be displayed on screen as shown in the following figure.



On this page, the test result is displayed in upper-case character. The measurement control parameters can be set in this page:

- Test function (FUNC)
- Test range (RANGE)
- Test frequency (FREQ)
- DC bias
- Test level (LEVEL)
- Test speed (SPEED)

There are 6 zones in this page: FUNC, RANG, FREQ, DC BIAS, LEVEL, SPEED. The details will be discussed later.

The test result/ condition display zone shows the information about test condition. These conditions can be set on <Measure> page or <Correction> page.

- Signal source voltage/ current monitor (**Vm, Im**)
- Open, short, load correction ON/OFF status (**CORR**)

3.1.1 3.1.1 Test function

In a measurement period, LM1050 can test four parameters for an impedance component: two primary parameters and two secondary parameters. Parameters that can be tested are as follows:

Primary parameters

- |Z| (Module of impedance)
- |Y| (Module of admittance)
- L (Inductance)
- C (Capacitance)
- R (Resistance)
- G (Conductance)
- DCR (DC resistance)

Secondary Parameters

- D (Dissipation factor)
- Q (Quality factor)
- Rs (Equivalent Series Resistance ESR)
- Rp (Equivalent Parallel Resistance)
- X (Reactance)
- B (Admittance)
- θ (Phase Angle)

Test results of primary and secondary parameters are respectively displayed in two lines in the form of upper-case characters. The primary parameter displays in the upper line while the secondary parameter displays in the lower line.

Operation steps for setting test function:

1) Move the cursor to FUNCA zone, the following soft keys will be displayed on the screen.

- Cp—...→
- Cs—...→
- Lp—...→
- Ls—...→
- Z—...→
- ↓

2) Press the soft key corresponding to Cp—...→, the following parameters will be shown for your choice.

- Cp-D
- Cp-Q
- Cp-G
- Cp-Rp
- ←

Press the soft key corresponding to your desired parameter. Then press ← to return to upper soft key menu.

3) Press Cs—...→, the following parameters will be shown for your choice.

- Cs-D
- Cs-Q
- Cs-Rs
- ←

Press the soft key corresponding to your desired parameter. Then press ← to return to upper soft key menu.

4) Press Lp—...→, the following parameters will be shown for your choice.

- Lp-D
- Lp-Q
- Lp-G
- Lp-Rp
- ←

Press the soft key corresponding to your desired parameter. Then press ← to return to upper soft key menu.

5) Press Ls—...→, the following parameters will be shown for your choice.

- Ls-D
- Ls-Q
- Ls-Rs
- ←

Press the soft key corresponding to your desired parameter. Then press ← to return to upper soft key menu

6) Press Z—...→, the following parameters will be shown for your choice.

- Z-d
- Z-r
- ←

Press the soft key corresponding to your desired parameter. Then press ← to return to upper soft key menu.

7) Press ↓, another group of soft keys will be shown.

- Y—...→
- R—...→
- G—B
- DCR
- ←

Press the soft key corresponding to your desired parameter. Then press ← to return to upper soft key menu.

8) Press Y—...→, the following parameters will be shown for your choice.

- Y-d
- Y-r
- ←

Press the soft key corresponding to your desired parameter. Then press ← to return to upper soft key menu.

9) Press R—...→, the following parameters will be shown for your choice.

- R-X
- Rp-Q
- Rs-Q
- ←

Press the soft key corresponding to your desired parameter. Then press ← to return to upper soft key menu.

Parameter setup of **FUNCB** is the same as that of **FUNCA**, but **FUNCB** can be turned off (**OFF**).

3.1.2 3.1.2 Test range

Measurement range should be selected in accordance with the impedance value of the tested LCR component.

LM1050 has 10 AC ranges: 1Ω, 10Ω, 30Ω, 100Ω, 300Ω, 1kΩ, 3kΩ, 10kΩ, 100kΩ and 1MΩ.

LM1050 has 10 DCR measurement ranges: 1Ω, 10Ω, 30Ω, 100Ω, 300Ω, 1kΩ, 3kΩ, 10kΩ, 100kΩ and 1 MΩ.

Operation steps for setting test range:

- 1) Move the cursor to the range zone, the following soft keys will be displayed:
 - **AUTO** The soft key is used to set the range mode to **AUTO**.
 - **HOLD** The soft key is used to switch the **AUTO** mode to the **HOLD** mode. When the range mode is set to **HOLD**, the range will be locked in the current measurement range. The current measurement range will be displayed in the range zone.
 - **↑(+)** The soft key is used to increase the range under **HOLD** mode.
 - **↓(-)** The soft key is used to decrease the range under **HOLD** mode.
- 2) Use soft keys to set measurement range.

3.1.3 3.1.3 Test frequency

The measurement range of LM1050 ranges from 20Hz to 5MHz with an increase or decrease of 0.01Hz. When the test function is set as DCR, the **FREQ** zone will display "----".

Operation steps for setting test frequency:

LM1050 provides two methods to set measurement frequency. The first one is to use soft keys and the other one is to input data by using numeric keys.

- 1) Move the cursor to the **FREQ** zone, the following soft keys will be displayed.
 - **↑(++)**
This is a coarse adjustment soft key used to increase the frequency. Press this key, the frequency will be increased to the next 10 times frequency point after 20 Hz.
 - **↑(+)**
This is a fine adjustment soft key used to increase the frequency. Press this key, the frequency will be increased to a higher frequency point. 10 frequency points can be set among 10 times frequency point.
 - **↓(-)**
This is a fine adjustment soft key used to decrease the frequency. The selectable frequencies are the same as that of **↑(+)**.
 - **↓(--)**
This is a coarse adjustment soft key used to decrease the frequency. The selectable frequencies are the same as that of **↑(++)**.
- 2) Use soft keys or numeric keys to select or set frequency. When using numeric keys to input the required frequency value, the soft key displays the available frequency units (**Hz**, **kHz** and **MHz**). You can use unit soft key to input unit and data. When using [ENTER] to input frequency, the default unit is Hz.

3.1.4 3.1.4 Test level

The measurement level of LM1050 can be set according to the RMS value of sine wave signal. The frequency of sine wave signal is the test frequency which is generated by inner oscillator. You can set measurement voltage or current. There are 4 kinds of signal source input impedance in LM1050. When the test function is DCR, the **FREQ** zone will display "---".

Note: The measurement current is the output one when the tested terminal is short, while the measurement voltage is the output one when the tested terminal is open.

The auto level control function of LM1050 can realize the measurement of constant voltage or current. The auto level control function (ALC) can be set as ON in <MEAS> page. When the auto level control function is set to ON, "*" will be displayed following the current level value. Refer to <MEAS> for more information.

Operation steps for setting test level:

LM1050 provides two methods to set the level of test signal source. The first one is to use soft keys, while the second one is to input data by numeric keys.

1) Move the cursor to LEVEL, the following soft keys will be displayed.

- **↑(+)**

This soft key is used to increase the level of test signal source.

- **↓(-)**

This soft key is used to decrease the level of test signal source.

2) Soft or numeric keys are used to select or set the test level. When numeric keys are used to input the desired level, the available units (mV, V, μ A, mA and A) will be displayed in the soft key zone. Users can use these unit keys to input unit and data. When [ENTER] is used to terminate the input of level, the default level is V or A.

NOTE: When you need to switch the level between current and voltage, numeric keys and unit soft keys must be used.

3.1.5 3.1.5 DC bias

LM1050 provides internal DC bias voltage of $-5V \sim +5V$. When the test function is selected as DCR, the bias zone will display "----".

Operation steps for setting DC bias:

LM1050 provides two methods to set the DC bias. The first one is to use soft keys, while the second one is to input data by numeric keys.

- 1) Move the cursor to DC BIAS, the following soft keys will be displayed.
 - $\uparrow (+)$
This soft key is used to increase the output level of DC bias.
 - $\downarrow (-)$
This soft key is used to decrease the output level of DC bias.
- 2) Soft or numeric keys can be used to select or set the DC bias source. When numeric soft keys are used to input the desired bias level, the available units (mV, V, μA , mA and A) will be displayed in the soft key zone. Users can use these soft keys to input unit or data. When [ENTER] is used to terminate the input of bias value, the default unit is V or A.

NOTE: When you need to switch the DC bias level between current and voltage, numeric keys and unit soft keys must be used.

Press the [DC BIAS] key on the front panel to allow the output of DC bias. When DC bias is permitted to output, the [DC BIAS] key will be lighted.

3.1.6 3.1.6 Test speed

The test speed of LM1050 is determined by the following factors:

- Integration time (A/D conversion)
- Average times (average test times per each test)
- Measurement delay (from startup to the start of measurement)
- Display time of test results

You can select test mode as FAST, MED or SLOW. Generally, the test result is more stable and accurate in SLOW test mode.

Operation steps for setting test speed:

- 1) Move the cursor to SPEED, the following soft keys will be displayed:
 - FAST
 - MED
 - SLOW
- 2) Use above soft keys to set the test speed.

3.1.7 3.1.7 Tools

The test result of LM1050 is displayed as 6 floating-point digits. Decimal point lock function can make LM1050 output the test result in fixed way. Meanwhile this function can change the displayed count of test result. This displayed result can be selected to be shown in large character or small character.

Operation steps for tools

Set the display mode of decimal point in fixed mode according to the following operation steps. Also the character size of test result can be set.

- 1) Move the cursor to MEAS RESULT DISP zone, the following soft keys will be displayed:
 - **D.P. AUTO**
 - **D.P. FIX**
 - **D.P. INCR +**
 - **D.P. INCR -**
- 2) Press **D.P. AUTO** to reset the decimal position of the primary or the secondary parameter test result to its default setting.
- 3) Press **D.P. FIX** to lock the decimal location of primary parameter TEST result.
- 4) Press **D.P. INCR +** to increase the displayed digit by ten times.
- 5) Press **D.P. INCR -** to decrease the displayed digit by ten times

NOTE: Under the following circumstance, the function of decimal lock will be cancelled automatically to recover to floating decimal point status.

- **Test function is changed.**
In deviation test, the deviation test mode (**ΔABS**, **Δ%**, **OFF**) is changed.
-

3.1.8 3.1.8 Save LCR test result by U disk

Users can use U disk to save LCR test result. The following test results and the saving format can be stored in U disk.

- 1) COMP-ON: primary parameter, secondary parameter, status (0 means normal), sorting result
COMP-OFF: primary parameter, secondary parameter, status (0 means normal)
- 2) DCR: DCR, primary parameter
- 3) LIST SCAN: list, primary parameter, secondary parameter, status (0 means normal), compare result (-1 means lower than the nominal value, while 1 means higher than the nominal value), line NO.

3.2 3.2 <BIN NO. DISP>

Press [**DISP**] firstly and then the **BIN NO.** soft key to enter into <BIN NO. DISP> display page. On this page, bin NO. is displayed in upper-case character while the test result, in lower-case character.



The following control parameters can be set on **<BIN NO. DISP>**.

- Compare function ON/OFF (**COMP**)

There are 2 zones: **BIN NO. DISP**, **COMP**. Their detailed information will be introduced as below.

The following test conditions are displayed in the measurement result/condition zone. These zones cannot be set on this page but can be set on **<MEAS SETUP>**, **<MEAS DISP>** or **<CORRECTION>**.

- Test function (FUNC)
- Test range (RANGE)
- Test frequency (FREQ)
- DC bias
- Test level (LEVEL)
- Test speed (SPEED)
- Compare (COMP)

3.2.1 3.2.1 Comparator function

LM1050 has an inserted compare function which can divide DUT to up to 10 bins (from BIN1 to BIN9 and BIN OUT). Users can set 9 pairs of primary parameter limit and one pair of secondary bin limit. If the primary parameter of DUT is within the range of the bin limit but the secondary parameter is outside of the bin limit, the DUT will be sorted into the auxiliary bin. When LM1050 has installed an HANDLER interface, the compare result will be output into the automatic test system and further realizing auto-sorting test. These limits can only be set on the **<LIMIT TABLE SETUP>** page. Users can set the compare function to ON or OFF in the **COMP** zone.

Operation steps for compare function

1) Move the cursor to **COMP**, the following soft keys will be displayed.

- ON
- OFF

2) Select one of above soft keys to set the compare function as ON or OFF.

3.3 <BIN COUNT DISP>

Press [DISP] and then select the soft key of **BIN COUNT** to enter into the **<BIN COUNT>** page which shows the count of each bin.

The screenshot shows the <BIN COUNT DISP> screen with the following content:

< BIN COUNT DISP >			
PARAM: Cp-D		NOM. : 0.00000pF	COUNT: OFF
BIN	LOW [F]	HIGH[F]	COUNT
1	---	---	0
2	---	---	0
3	---	---	0
4	---	---	0
5	---	---	0
6	---	---	0
7	---	---	0
8	---	---	0
9	---	---	0
2nd	---	---	[]
AUX : OFF		OUT :	0

At the bottom left of the screen, it says "Keys locked". On the right side, there is a vertical menu with the following options: MEAS DISP, BIN NO., BIN COUNT, LIST SWEEP, MULTI PARA., and MORE 1/2. At the bottom right, the time "14:19" is displayed.

The following control parameters can be set on the **<BIN COUNT>** page.

- Count function ON/OFF (**COUNT**)

There are 2 zones are displayed in this page: **BIN COUNT DISP**, **COUNT**. The function of each zone will be introduced as below.

The following test result/ condition can be displayed in this page but cannot be set in this page. Users can set them on the **<LIMIT TABLE SETUP>** page.

- Test parameter (PARAM)
- Nominal value (NOM)
- Bin limit value (HIGH/ LOW)

3.3.1 3.3.1 PARAM

Parameter zone shows the "Function" parameter, if user selects primary and secondary parameter swap compare mode, the parameter will be displayed as swap parameter, such as: "Cp-D" is displayed as "D-Cp", which means the current D is compared as primary parameter while Cp is compared as secondary parameter.

3.3.2 3.3.2 NOM.

Nominal parameter is the nominal value used to make bin compare.

3.3.3 3.3.3 BIN

This zone shows the bin number of the limit list. "2nd" means the secondary parameter limit.

3.3.4 3.3.4 HIGH/LOW

This zone shows the high and the low limits of the limit list.

3.3.5 3.3.5 COUNT

This zone shows the count value of the current bin.

3.3.6 3.3.6 AUX

This zone shows the count value of the auxiliary bin.

3.3.7 3.3.7 OUT

This zone shows the count value of the out bin.

Operation steps for bin count function

Execute the following operations to set the bin count function ON/OFF on <**BIN COUNT DISP**> page.

- 1) On <**BIN COUNT DISP**> page, move the cursor to **COUNT** zone, the following soft keys will be displayed.
 - **ON**
 - **OFF**
 - **RESET**
- 2) Press the soft key **ON** to turn on the count function.
- 3) Press the soft key **OFF** to turn off the count function.
- 4) Press the soft key **RESET**, "⊕ : Reset count, Sure?" will be displayed in the help zone. Then the following soft keys will be displayed.
 - **YES**
 - **NO**
- 5) Press the soft key **YES** to reset all bin counts to 0.
- 6) Press the soft key **NO** to cancel the reset operation.

3.4 3.4 <LIST SWEEP DISP>

Up to 10 test frequencies, test levels or DC bias can be set on this page. Users can set the high and the low limits for each list-sweep test point. Auto sweep test will be made on these test points. And their test results will be compared with their limits.

Press down the menu key [**DISP**] and then the soft key **LIST SWEEP** to enter into the <**LIST SWEEP DISP**> page, shown as below.



Test points will be automatically tested in a scanning mode. Meanwhile, comparison will be made between test results and limit values. In the process of list sweep test, ">" denotes the current sweep test point. The following control parameters can be set on <LIST SWEEP DISP>.

■ Sweep mode (**MODE**)

There are 2 zones on this page: **LIST SWEEP DISP** and **mode**. List sweep points cannot be set on this page but can be set on <LIST SWEEP SETUP>.

3.4.1 3.4.1 Sweep mode

The list sweep function of LM1050 can make automatic sweep test for up to 10 points' test frequencies, test levels or DC bias. Two sweep modes are available on LM1050: SEQ and STEP. In SEQ mode, each press of [TRIGGER] will direct LM1050 to automatically test all list sweep test points. In STEP mode, each press of [TRIGGER] will direct LM1050 to test one list sweep point.

NOTE: When the trigger mode is set to INT, sweep test modes of SEQ and STEP will not be controlled by [TRIGGER].

When the trigger mode is set to MAN, [TRIGGER] can be used to trigger the list sweep test.

Operation steps for setting the list sweep mode:

Set the sweep mode on the <LIST SWEEP DISP> page as **SEQ** or **STEP**.

1) On the <LIST SWEEP DISP> page, move the cursor to the **MODE** zone, the following soft keys will be displayed:

- **SEQ**
- **STEP**

2) Press **SEQ** to set the sweep mode as sequential sweep test mode.

3) Press **STEP** to set the sweep mode as single step sweep test mode.

3.4.2 3.4.2 FREQ (Hz)

This zone shows the currently swept parameter mode and its unit. What are right below this item are parameters of the sweep list.

3.4.3 3.4.3 Ls[H] Q[]

This zone is the currently swept Function parameter and its unit. What are right below this item are the sweep results.

3.4.4 3.4.4 CMP (Compare)

This zone indicates the compare results of the currently swept points. L means the result is lower than the standard and H is higher than the standard, while blank is medium.

3.5 3.5 <MEASURE SETUP>

Press [SETUP] to enter into the <MEASURE SETUP> page shown as below:

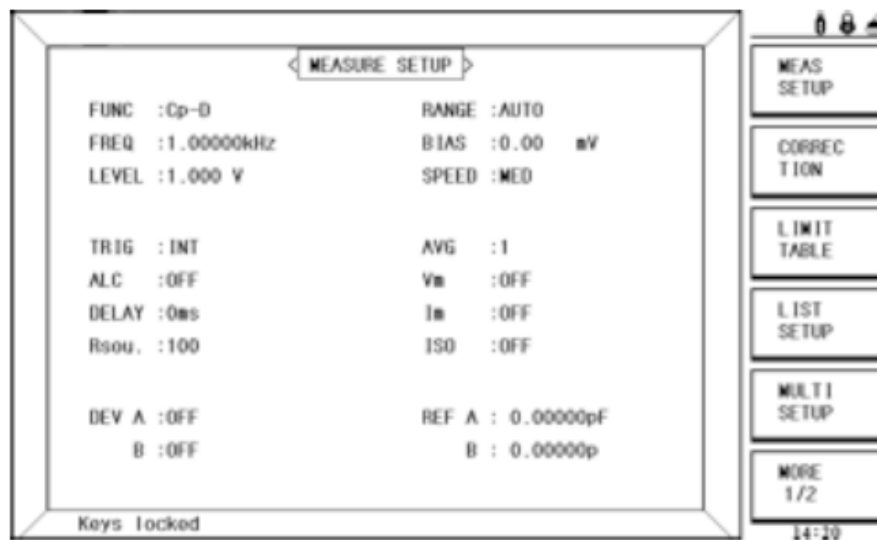

In this page, the following control parameters can be set. (Items in parenthesis can be set)

- Test function (**FUNC**)
- Test range (**RANGE**)
- Test frequency (**FREQ**)
- DC bias
- Test level (**LEVEL**)
- Test speed (**SPEED**)
- Trigger Mode (**TRIG**)
- Auto Level Control (**ALC**)
- Delay Time (**DELAY**)
- Output Resistance (**Rsou.**)
- Average times (**AVG**)
- Voltage Level Monitor ON/ OFF (**Vm**)
- Current Level Monitor ON/ OFF (**Im**)
- Bias Current Isolation ON/ OFF (**ISO**)
- Deviation Test Mode A (**DEV A**)
- Deviation Test Mode B (**DEV B**)
- Deviation Test Reference Value A (**REF A**)
- Deviation Test Reference Value B (**REF B**)

Some zones listed below are as same as that on <MEAS DISP> page, so it is not necessary to introduce in this section, but others will be introduced briefly in the following sections.

- Test function (FUNC)
- Test range (RANGE)
- Test frequency (FREQ)
- DC bias
- Test level (LEVEL)
- Test speed (SPEED)

3.5.1 3.5.1 Trigger mode

There are 4 trigger modes on LM1050: INT, MAN, EXT and BUS.

When the trigger mode is set as INT, LM1050 will make sequential and repeated tests.

When the trigger mode is set as MAN, press [TRIGGER] once, LM1050 will make one test. When the trigger mode is set as EXT, once the HANDLER interface receives a positive impulse, LM1050 will execute one measurement.

When the trigger mode is set as BUS, once the IEEE 488 interface receives a TRIGGER command, LM1050 will execute a test. The BUS mode cannot be set on the front panel.

 Note: In the process of testing, when LM1050 receives a trigger signal, it will be ignored. So the trigger signal should be sent after the test is done. When optional HANDLER interface triggers LM1050, the trigger mode is set as EXT.

Operation steps for the trigger mode setup

Execute the operation of other trigger modes except BUS trigger. If BUS trigger mode is necessary, then use IEEE4888 interface to send **TRIGger:SOURce BUS** command.

- 1) Move the cursor to the **TRIGGER** zone, the following soft keys will be displayed:
 - **INT**
 - **MAN**
 - **EXT**
- 2) Use above soft keys to set the trigger mode.

3.5.2 3.5.2 Auto level control function

Auto level control function can adjust the real test level (voltage across or current through DUT) to the test level value. This function can guarantee the test voltage or current being constant.

When using this function, the test level can be set within the range below:

The range of constant voltage: 10 mV_{rms} to 5 V_{rms}

The range of constant current: 100 µA_{rms} to 100 mA_{rms}

NOTE: When the constant level function is valid, if the level exceeds above ranges, this function will be automatically set as OFF. The level value currently set is generally deemed as non-constant level value.

Operation steps for setting auto level control function

Execute the following steps and set the constant level function as ON or OFF.

- 1) Move the cursor to **ALC** zone, the following soft keys are displayed.
 - **ON**
 - **OFF**
- 2) Press **ON** to turn on the auto level control function.
- 3) Press **OFF** to turn off the auto level control function.

3.5.3 3.5.3 Bias current isolation function

Reserved function

3.5.4 3.5.4 Average

The AVERAGE function can calculate the average value of two or more test results. The average times can be set from 1 to 255 with an increase or decrease of 1. Operation steps for setting test average times.

- 1) Move the cursor to the **AVG** zone, the following soft keys are displayed.

- 

This key is used to increase the average times.

- 

This key is used to decrease the average times.

- 2) Use above soft keys to set the average times or use numeric keys and **[ENTER]** input average times directly.

3.5.5 3.5.5 Level monitor function

The level monitor function can monitor the real voltage across DUT or real current through DUT. The monitored voltage value is displayed in **Vm** zone on **<MEASURE DISP>** page while the monitored current value is in **Im** zone.

Note: The correction function can influence the level monitor function, so when the correction data changes the level monitor value will change. When the correction is switched between OPEN or SHOR or LOAD, the level monitor value will be influenced as well

Operation steps for setting the level monitor function

Execute the following operation steps to set the level monitor function as ON or OFF.

- 1) Move the cursor to **Vm** zone, the following soft keys will be displayed.
 - **ON**
 - **OFF**
- 2) Press **ON** to set the voltage monitor function as ON while press **OFF** to set the voltage monitor function as OFF.
- 3) Move the cursor to **Im** zone, the following soft keys will be displayed.
 - **ON**
 - **OFF**
- 4) Press **ON** to set the current level monitor function as ON while press **OFF** to set the current level monitor function as OFF.

3.5.6 3.5.6 Delay time

LM1050 trigger delay means the delay time from triggering to test-start. Delay function can set the trigger delay time. When the list sweep test function is used, all set delay time will be delayed at each sweep test point. The range of the trigger delay time can be set from 0s to 60s with 1ms as the resolution. The trigger delay function is great useful when the instrument is applied in an auto test system. When the instrument is triggered by HANDLER interface, the trigger delay time can ensure DUT and test terminal has a reliable contact.

Operation steps for setting the delay function

Execute the following steps to set the measurement delay time.

- 1) Move the cursor to the **DELAY** zone.
- 2) Use numeric keys to input delay time. After pressing a numeric key, the following unit keys will be displayed. These soft keys can replace **[ENTER]** to input delay time.
 - **msec**
 - **sec**

3.5.7 3.5.7 Output impedance

LM1050 provides four output impedances for your choice: 100 Ω , 50 Ω , 30 Ω and 10 Ω . When testing inductance, it is necessary to input the same output impedance so as to make data comparison with other instruments.

Note: When an optional bias board is selected, only 100 Ω is available. Operation steps for setting output resistance

Execute the following operations to set output impedance

- 1) Move the cursor to the **Rsou** zone, the following soft keys will be displayed.
 - 100
 - 30
 - 50
 - 10/CC
- 2) Press **100 Ω** to select the output impedance as 100 Ω . Press **30 Ω** to select the output impedance as 30 Ω .

3.5.8 3.5.8 Deviation test function

The deviation test function can make the deviation value (instead of real test value) be directly displayed on the screen. The deviation value is equivalent to the real test value subtracting the pre-set reference value. This function brings great convenience to observe variations of component parameters with temperature, frequency, bias. Bias test function can be used for primary or secondary parameter or primary and secondary parameters meanwhile. The instrument provides two deviation test modes as below:

■ Δ ABS (Absolute Deviation mode)

The deviation currently displayed is the difference between the test value of the DUT and the preset reference value. The formula of calculating Δ ABS is as below:

$$\Delta\text{ABS} = X - Y$$

Where, X is the test value of DUT

Y is the preset reference value.

■ $\Delta\%$ (Percentage deviation mode)

The deviation currently displayed is the percentage of the difference between the test value of DUT and the preset reference value divided by the reference value.

Its calculating formula is as below:

$$\Delta\% = (X - Y) / Y * 100[\%]$$

Where, X is the test value of DUT.

Y is the preset reference value.

Operation steps for setting deviation test function

- 1) Move the cursor to the **REF A** zone to input the reference value of the primary parameter, the following soft key will be displayed.
 - **MEAS**

When the reference component is connected with the test terminal, you should press **MEAS**. Then LM1050 will test the reference component and the test result will be automatically input as the value of **REF A**.
- 2) Use **MEAS** or numeric keys to input the reference value of primary parameter.
- 3) Move the cursor to the **REF B** to input the reference value of the secondary parameter, the following soft key will be displayed.
 - **MEAS**

When the reference component is connected to the test terminal, you should press **MEAS**. Then LM1050 will test the reference component and the test result will be automatically input as the value of **REF B**.
- 4) Use **MEAS** or numeric keys to input the reference value of the secondary parameter. If the reference values of primary and secondary parameters have been set in steps 2), you can skip this step.
- 5) Move the cursor to the **DEV A** zone, the following soft keys will be displayed:
 - **ΔABS**
 - **Δ%**
 - **OFF**
- 6) Use above soft keys to set the deviation mode of the primary parameter.
- 7) Move the cursor to the **DEV B** zone, the following soft keys will be displayed.
 - **ΔABS**
 - **Δ%**
 - **OFF**
- 8) Use above soft keys to set the deviation mode of the secondary parameter.

3.6 <CORRECTION>

Press **[SETUP]** to select **CORRECTION** to enter into the **<CORRECTION>** page.

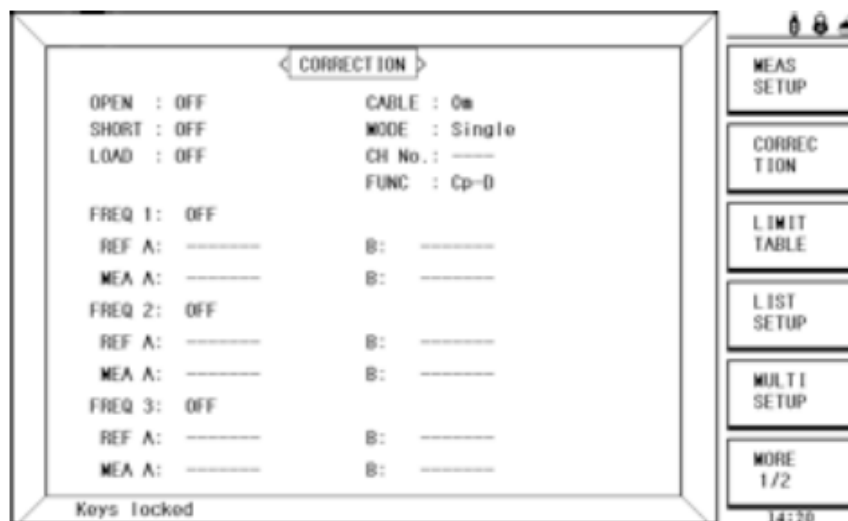

Open, short and load correction on the **<CORRECTION>** page can be used to eliminate the distribution capacitance, spurious impedance and other measurement errors. LM1050 provides two correction modes: the first one is executing open and short correction on all frequency points through interpolation method; the other one is executing open, short and load correction on the frequency point currently set. The following measurement control parameters can be set on the **<Correction>** page.

- Open correction (**OPEN**)
- Short correction (**SHORT**)
- Load correction (**LOAD**)
- Cable length selection (**CABLE**)
- Single/ multiple correction mode selection (**MODE**)
- Frequency points of OPEN, SHOR and LOAD (**FREQ 1, FREQ 2, FREQ3**)
- Reference values for 3 frequency points of load correction (**REF A, REF B**)

There are 16 zones on this page: **Correction, Open, Short, Load, Cable, Mode, Function, FREQ 1, REF A, REF B, FREQ 2, REF A, REF B, FRQ 3, REF A, REF B**. Each control function zone will be introduced in the following paragraphs. Besides above setting zones, the **<CORRECTION>** page will also display the following monitoring zones. The monitoring zones are similar with the setting zones, but the monitoring zones can only provide reference information and you cannot change state or parameter of these zones.

- Real test results of the load correction (**MEA A, MEA B**)
 - Under the multiple correction mode, display the current channel number (**CHNO.**)
- The real test results of load correction can be tested on **FREQ1, FREQ2** and **FREQ3**. Channels of the current multiple correction mode can be set through the multiple-channel sweep interface or IEEE 488 interface.

3.6.1 3.6.1 OPEN

The open correction function of LM1050 can eliminate the error caused by the stray admittance (G, B) parallel-connected with DUT, shown as figure 3-1.

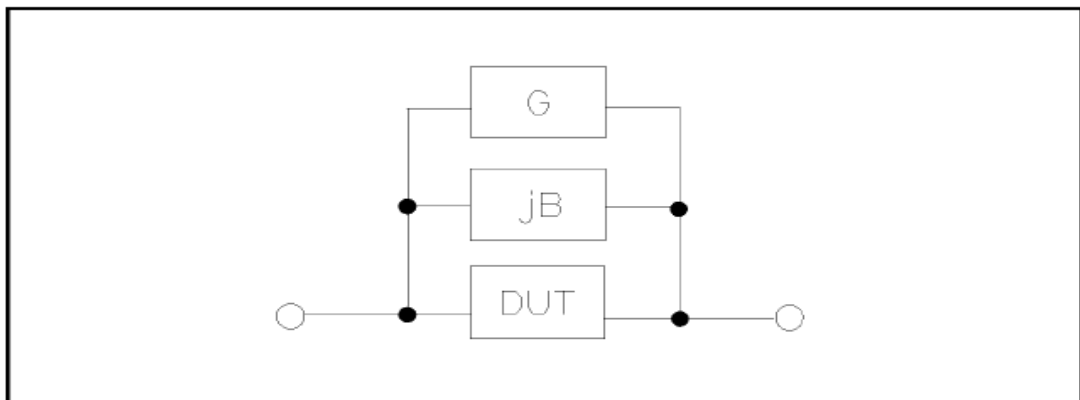

Figure 1 Stray Admittance

LM1050 adopts the following two kinds of open correction data:

- LM1050 will automatically make open correction test on 41 fixed frequency points no matter what the currently set frequency is. Based on the open correction data of the following 41 frequencies, the instrument can calculate all open correction data of different test ranges which corresponds to all test frequencies. Move the cursor to **OPEN** and then used **ALL** to execute full frequency open correction.

Shown as the figure.

			20	25	30	40	50	60	80	[Hz]
100	120	150	200	250	300	400	500	600	800	[Hz]
1	1.2	1.5	2	2.5	3	4	5	6	8	[kHz]
10	12	15	20	25	30	40	50	60	80	[kHz]
100	120	150	200	250	300	400	500	600	800	[kHz]
1	1.2	1.5	2	2,5	3	4	5			[MHz]

- 3 open correction frequencies can be set in **FREQ** on **<CORRECTION>**: FREQ 1, FREQ 2 and FREQ 3. Move the cursor to **FREQ 1**, **FREQ 2**, **FREQ 3**, and then use the **SINGLE** soft key to set the three frequencies respectively.

Operation steps of open correction function

- 1) Move the cursor to OPEN, the following soft keys will be displayed:
 - **ON**
 - **OFF**
 - **ALL**
 - **DCR**
- 2) Connect test fixture to test terminal. The fixture is open and not connecting to any DUT.
- 3) Press **ALL**, LM1050 will test the open admittance (capacitance and inductance) under 41 frequencies. It will take about 75 seconds to finish the open full-frequency correction. In the process of correction , the following soft key will be displayed:
 - **ABORT**

This soft key can be used to terminate the current open correction operation and reserve the formal open correction data.
- 4) Press **DCR**, LM1050 will test the open-circuit resistance under the DC resistance function.
- 5) Press **ON** to turn on the function of open-circuit correction, then LM1050 will perform open-circuit correction calculation in the later testing process. IF FREQ 1, FREQ 2 and FREQ 3 are set as OFF, the open-circuit correction data of the current frequency will be calculated by imbedding algorithm. When FREQ 1, FREQ 2 and FREQ 3 are set as ON, the value of the current test frequency will be that of FREQ 1, FREQ 2 or FREQ 3, in this case, the open correction data of FREQ 1, FREQ 2 or FREQ 3 will be used to the calculation of open correction.
- 6) Press **OFF** to turn off the open correction function. In later measurement, no open correction calculation will be taken.

3.6.2

3.6.2 SHORT

The short correction function of LM1050 can eliminate the error caused by spurious inductance (R, X) in serial with DUT as shown in figure 3-2.

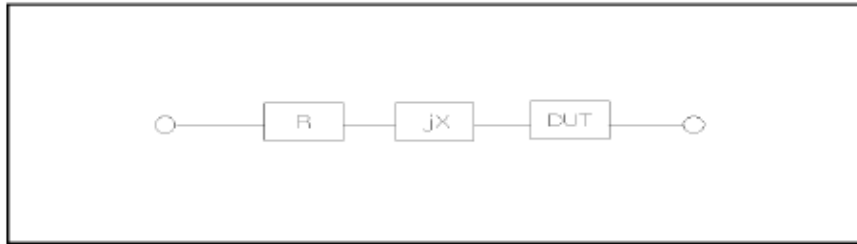

Figure 3-2 Spurious Inductance

LM1050 adopts two kinds of short correction data.

- No matter what the current frequency is, LM1050 will execute short correction test on the 41 fixed frequency points. Except the 41 frequencies, the instrument will adopt imbedding algorithm to calculate the short correction data of different test frequencies which correspond to different ranges. Move the cursor to the **SHORT** zone, and then use the **ALL** soft key to execute full frequency open correction. The 43 fixed frequencies are the same as that in open correction.
 - LM1050 can set 3 short correction frequencies in the **FREQ** zone on the **<CORRECTION>** page: FREQ 1, FREQ 2 and FREQ 3. Move the cursor to **FREQ 1**, **FREQ 2** or **FREQ 3** and then use **ALL** to short correct the three set frequencies.

Operation steps of short correction function

Short correction includes full frequency short correction which adopts imbedding algorithm and single frequency short correction on 3 frequencies. Execute the following operation steps to make short correction. The single frequency short correction can refer to "Load correction".

- 1) Move the cursor to the **SHORT** zone, the following soft keys will be displayed:
 - **ON**
 - **OFF**
 - **ALL**
 - **DCR**
- 2) Connect the test fixture to the test ports. Short the test fixture by using short plate.
- 3) Press the **ALL** soft key, LM1050 will test the short spurious impedances (resistance and reactance) of 41 frequencies. Short full frequency correction takes about 75 seconds and in this process, the following soft keys will be displayed.
 - **ABORT**

This soft key can be used to cancel the current short correction operation and reserve the formal open correction data.
- 4) Press **DCR**, LM1050 will test the short resistance under DC resistance function.
- 5) Press **ON** to validate the short correction function. LM1050 will make short correction calculation in latter test. If FREQ 1, FREQ 2 and FREQ 3 are set as OFF, the short correction function will calculate the short correction data of the current frequency. If FREQ 1, FREQ 2 and FREQ 3 are set as ON and the current frequency is FREQ 1, FREQ 2 or FREQ 3, the short correction data of FREQ 1, FREQ 2 or FREQ 3 will be used in the calculation of the short correction.
- 6) Press **OFF** to turn off the short correction function. In latter test, no short correction calculation will be performed. ^

3.6.3

3.6.3 LOAD

By using transport coefficient between the real test value and the standard reference value at the preset frequency (**FREQ 1**, **FREQ 2** or **FREQ 3**), the load correction of LM1050 can eliminate the test error. It is obvious that open, short, and load correction can be performed at preset frequencies. The 3 preset frequencies can be set in the setup zones of **FREQ 1**, **FREQ 2** and **FREQ 3**. The standard reference values can be set in the setup zones of **REF A** and **REF B**. The standard test function must be set in the **Func** zone before setting standard reference value. When the cursor moves to **FREQ 1**, **FREQ 2** or **FREQ 3**, the **LOAD** soft key will be displayed. Press **LOAD** to perform the load correction test.

Operation steps for setting load correction

According to the following steps, perform open/ short/ load correction test at preset frequencies.

1) Move the cursor to **FREQ 1**, **FREQ 2** or **FREQ 3**, the following soft keys will be displayed:

■ **ON**

Press this soft key to make the open/short/load correction data be available.

■ **OFF**

Press the soft key to make the open/short/load correction data be unavailable.

■ **OPEN SINGLE**

Press this soft key to execute open correction at **FREQ 1**, **FREQ 2** or **FREQ 3**.

■ **SHORT SINGLE**

Press this soft key to execute short correction at **FREQ 1**, **FREQ 2** or **FREQ 3**.

■ **LOAD**

Press this soft key to execute the load correction at **FREQ 1**, **FREQ 2** or **FREQ 3**.

2) Press the soft key **ON**, the original preset open/short/load correction frequency is displayed on the frequency setting zone.

3) Use numeric keys to input the correction frequency. After pressing any numeric key, the available unit keys (**Hz**, **kHz** and **MHz**) will be displayed on the soft key zone and these soft keys can replace the **[ENTER]** key to input correction frequency. When the **[ENTER]** key is used to input correction frequency, the default unit is Hz.

4) Connect the test fixture to the test terminal.

5) Make the test fixture be open.

6) Press **OPEN ALL** to perform open correction at the current set frequency. The test result (G, B) of the open correction test will be displayed in the help line (the bottom line).

7) Move the cursor to **OPEN**.

8) Press **ON** to perform the open correction calculation at preset frequency in latter measurements.

9) Move the cursor to **FREQ 1**, **FREQ 2** or **FREQ 3** to set the required correction frequency.

10) Make the test fixture be short.

11) Press **SHORT ALL** to perform short correction at preset frequency. The test result (R, X) of the short correction will be displayed in the help line (the bottom line).

12) Move the cursor to **SHORT**.

13) Press **ON** to perform the short correction calculation at preset frequency in latter measurements.

14) Prepare a standard test component.

15) Move the cursor to **FUNC**.

16) Set the function parameters required to be set.

17) Move the cursor to **REF A**.

18) Use numeric keys and unit keys to input the primary reference values of the standard component.

19) Move the cursor to **REF B**.

- 20) Use numeric keys and unit keys to input the secondary reference value of the standard component.
- 21) Move the cursor to the corresponding **FREQ 1**, **FREQ 2** or **FREQ 3**.
- 22) Connect the standard component to the test fixture.
- 23) Press **LOAD**, the instrument will execute a load correction. The real test results of the standard component will be displayed in **MEAS A** and **MEAS B**.
- 24) Move the cursor to **LOAD**.
- 25) Press **ON** to perform load correction calculation at preset frequencies in latter measurements.

3.6.4 3.6.4 Load correction test function

When performing load correction, the reference value of the standard component is required to be input in advance. The test parameters of reference value should conform with the preset load correction test function.

Load correction function adopts the transport coefficient between the real test value of preset frequency and the standard reference value to eliminate the test error. Load correction function is only available for calculating transport coefficient.

Operation steps for setting load correction test function

Refer to section 3.1.1.

3.6.5 3.6.5 Cable length selection

The available cable length is 0m, 1m, 2m and 4m.

3.6.6 3.6.6 Single/ multi correction mode

Refer to the instruction of the scanting optional interface.

3.7 <LIMIT TABLE>

Press [**SETUP**] and then **LIMIT TABLE** to enter into the <LIMIT TABLE SETUP> page as the following figure shown.



Compare function can be set on this page. LM1050 can set 9 bin limits of primary parameters and one of secondary parameters. The tested result can be divided into up to 10 bins (BIN 1 to BIN 9 and BIN OUT). If the primary parameter of DUT is within the limit range from BIN1 to BIN9, but the secondary parameter is out of the limit range, in this case the DUT will be sorted into aux bin. When LM1050 installs the HANDLER interface and it is used in automatic sorting system, the compare function will be especially useful. The following limit parameter of compare function only be set on <LIMIT TABLE SETUP> page.

- Test parameter (**PARAM**)
- Limit mode of compare function (**MODE**)
- Nominal value (**NOM**)
- Auxiliary bin ON/OFF (**AUX**)
- Compare function ON/OFF (**COM**)
- Low limit of each bin (**LOW**)
- High limit of each bin (**HIGH**)

3.7.1 3.7.1 Swap parameter

The swap parameter function can swap the primary and the secondary parameter in **PARAM**. For example, when the test parameter is Cp-D, the swap parameter function can change the test parameter as D-Cp. Then user can set 9 pairs of compare limits for D, but only 1 pair of compare limit can be set for Cp.

Operation steps for the swap parameter function

Execute the following operations to swap the primary and the secondary parameters.

- 1) Move the cursor to **PARAM**, the following soft key will be displayed.
 - **SWAP PARAM**
- 2) Press **SWAP PARAM** to swap the primary and the secondary parameters.
- 3) Press **SWAP PARAM** to swap the primary and the secondary parameter, which is to recover the formal setup.

3.7.2 3.7.2 Limit modes of compare function

Compare functions has two limit setup modes for primary parameters as shown in figure 3-3.

■ Tolerance mode

Under tolerance mode, set the deviation value of the nominal one (be set in the **NOM** zone) as the compare limit value. Deviation value has two modes: percentage deviation and absolute deviation.

■ Sequential mode

Under sequential mode, the range of the test value is the compare limit value. The compare limit value should be set in the order from small to large.

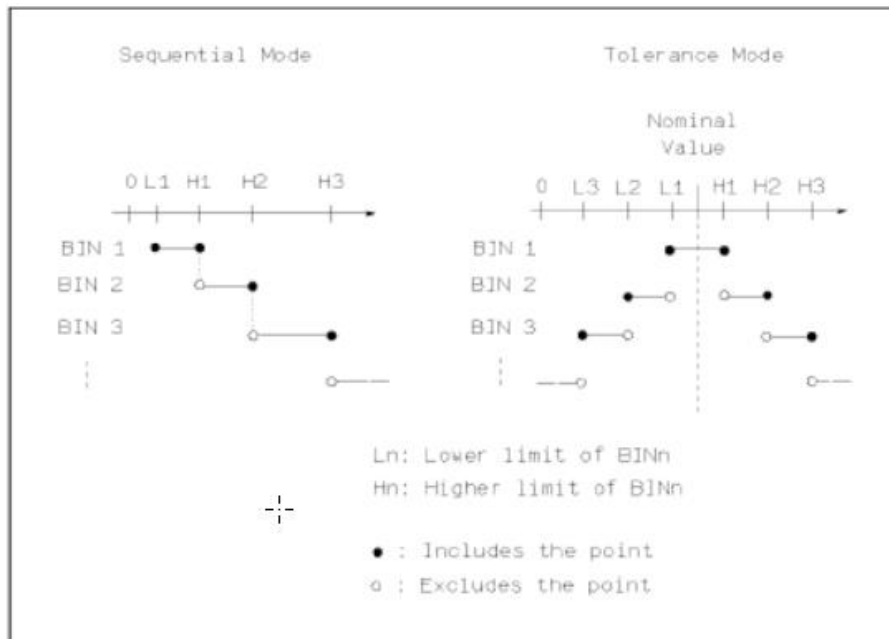

Figure 3-3 Tolerance mode and Sequential mode

Note: When setting limit values of tolerance mode, the error range should be set in the order from small to large. If the error range of BIN1 is the largest one, then all DUT will sort into BIN 1.

Under tolerance mode, the low limit is not necessary to be smaller than the nominal value and the high limit is not necessary to be larger than the nominal value. The limit range of each bin can be discontinues or overlapped.

Operation steps for setting the limit mode of the compare function

1 Move the cursor to the **MODE** zone, the following soft keys will be displayed.

■ %TOL

This soft key is used to set the limit mode as the tolerance mode of percentage deviation (% TOL).

■ ABS TOL

This soft key is used to set the limit mode as the tolerance mode of absolute deviation (ABS TOL).

■ SEQ MODE

This soft key is used to set the limit mode as sequential mode.

2) Use above soft keys to set the limit mode.

3.7.3 3.7.3 Set nominal value of tolerance mode

When the tolerance mode is selected as the limit mode of the primary parameter, it is necessary to set the nominal value. The nominal value can be any one within the display range.

When the sequential mode is selected as the limit mode the primary parameter, the nominal value can be set, but it is not necessary to use it under this mode.

Operation steps for setting the nominal value

- 1) Move the cursor to **NOM**.
- 2) Use numeric keys to input nominal value. After inputting the data, the following soft keys (**p, n, μ, m, k, M, *1**) can replace the **[ENTER]** key to input the nominal value. When using **[ENTER]** to input the nominal value, the default unit is the same as that input last time. Press ***1** to input nominal value, the instrument will select F, H or Ω as the default unit of the nominal value according to primary parameter.

3.7.4 3.7.4 Comparator function ON/OFF

LM1050 can set 9 bin limits of primary parameters and 1 bin limit of secondary parameters. The tested results can be sorted into 10 bins (BIN 1 to BIN 9 and BIN OUT) at most. If the primary parameter of DUT is within the limit range from BIN 1 to BIN 9, but the secondary parameter is out of the limit range, in this case the DUT will be sorted into aux bin. When LM1050 installs the HANDLER interface and it is used in the automatic sorting system, the compare function will be especially useful.

Operation steps for setting the compare function ON/OFF

- 1) Move the cursor to **COMP**, the following soft keys will be displayed.
 - **ON**
 - **OFF**
- 2) Use above soft keys to set the compare function as ON or OFF.

3.7.5 3.7.5 Auxiliary bin ON/OFF

When it is necessary to sort the secondary parameters, the limits of the secondary parameter can be set in **HIGH** and **LOW** of 2nd.

Three cases may occur in the process of secondary parameter sorting:

- On **<LIMIT TABLE SETUP>** page, no low / high limit of the secondary parameters has been set.
- On **<LIMIT TABLE SETUP >** page, the low/high limit of secondary parameters has been set but **Aux** function is set as OFF.

In this case, only those components whose secondary parameters are qualified can perform primary parameter sorting according to sorting limits. If the secondary parameters are unqualified and the corresponding primary parameters are within limit ranges, those components will be sorted into BIN OUT.

- On **<Limit list setup>** page, the low/high limit of the secondary parameters has been set and the **Aux** function is set as ON.

If the primary parameter is out of the limit range, it is sorted into BIN OUT. If the primary parameter of DUT is within the limit range but its secondary parameter is out of the limit range, the DUT will be sorted into the **Aux** bin.

Note: When the secondary parameter only has low limit and the auxiliary bin is set as ON, if the primary parameter of DUT is within the limit range and the secondary parameter is smaller than or equal to its low limit, the DUT will be sorted into the auxiliary bin. When the secondary parameter only has high limit and the auxiliary bin is set as ON, if the primary parameter of DUT is within the limit range and the secondary parameter is larger than or equal to its high limit, the DUT will be sorted into the auxiliary bin.

Operation steps for setting the auxiliary bin function ON/OFF

- 1) Move the cursor to **AUX**, the following soft keys will be displayed.
 - **ON**
 - **OFF**
- 2) Use above soft keys to set the auxiliary function as ON or OFF.

3.7.6 3.7.6 HIGH/LOW

LM1050 can set bin limits of 9 primary parameters and one secondary parameter. The test results can be sorted into 10 bins at most (BIN 1 to BIN 9 and BIN OUT). The high/low limits of primary parameters can be set in high limit and low limit of bins from BIN 1 to BIN 9. The limit of the secondary parameter can be set in **HIGH** and **LOW** of 2nd.

Operation steps for setting high/low limit

Execute the following steps to set sorting limits.

- 1) Set **PARAM** and **NOM** in the compare function menu and the limit **MODE** of the primary parameter.
- 2) Move the cursor to Low limit of BIN 1. If you select tolerance mode, the following operation steps should be from step 3 to step 6; if you select sequential mode, the following operation steps should be from step 7 to step 11.
- 3) User numeric keys to input low limit value in Low limit. After inputting the data, you can use (**p, n, μ , m, k, M, *1**) to replace **[ENTER]** to input the limit value. When **[ENTER]** is used, the default unit is the same as that being input last time. When pressing ***1**, the default unit will be F, H or Ω . After inputting limit value in **LOW** of BIN 1, the low limit of BIN 1 will be automatically set as - (absolute limit) and the high limit will be + (absolute limit).
- 4) The cursor will automatically move to **LOW** of BIN 2. Repeat step 3 until the limits of BIN 9 are input. Then the cursor will automatically move **LOW** of 2nd.
- 5) After inputting the low limit of the secondary parameter, the cursor will automatically move to **HIGH** of 2nd.
- 6) Input the high limit of the secondary parameter.
- 7) In Low limit of BIN 1, use numeric keys to input the low limit. After inputting the data, you can use (**p, n, μ , m, k, M, *1**) to replace **[ENTER]** to input the limit value. When **[ENTER]** is used to input the limit value, the default unit is the same as that being input last time. When pressing ***1**, the default unit will be F, H or Ω .
- 8) After inputting the low limit of BIN 1, the cursor will automatically move to **HIGH** of BIN 1. Input the high limit of BIN 1.
- 9) The cursor will automatically move **HIGH** of BIN 2. For the limit mode is sequential mode, the low limit of BIN 2 will be the high limit of BIN 1. Input the high limit of BIN 2.
- 10) Repeat step 9 until the high limit of BIN 9 is input. Then the cursor will automatically move to **LOW** of 2nd. Input the low limit of the secondary parameter.
- 11) The cursor will automatically move to **HIGH** of 2nd. Input the high limit of the secondary parameter.

3.8 3.8 <LIST SWEEP SETUP>

Press **[SETUP]** and then **LIST SWEEP** to enter into the **<LIST SWEEP SETUP>** page as shown below.

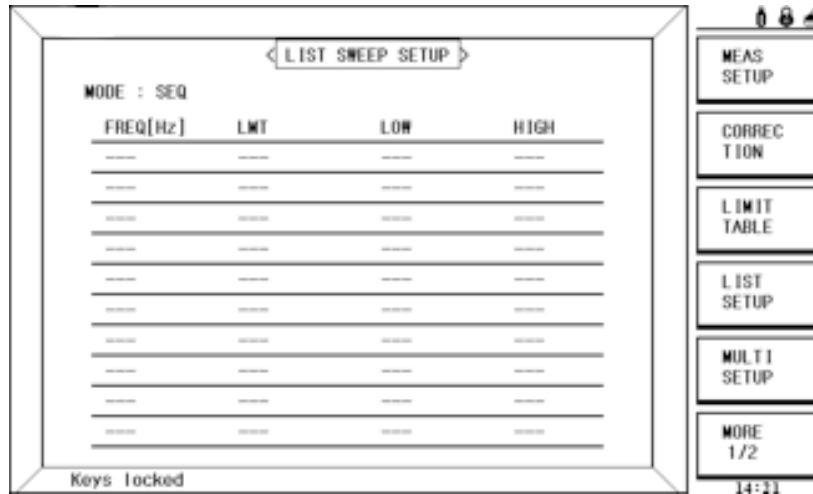

The list sweep function of LM1050 can perform auto sweep test for the test frequency, test level or bias voltage of 10 points. On **<LIST SWEEP SETUP>** page, the following list sweep parameters can be set.

- Sweep mode (**Mode**)
- Sweep parameter setup (frequency [**Hz**], level [**V**], level [**I**], bias [**V**], bias [**I**])
- Sweep test point setup (sweep point)
- Selection of limit parameter (**LMT**)
- High/low limit (**HIGH**, **LOW**)

36

3.8.1 3.8.1 MODE

Mode menu is the same as the mode on <List sweep display> page.

3.8.2 3.8.2 Test parameter

Sweep parameters can be: frequency [**Hz**], level [**V**], level [**I**], bias [**V**], bias [**I**].

Operation steps for setting test parameter

1) Move the cursor the line following **MODE**; the following soft keys will be displayed.

- **FREQ [Hz]**
- **LEVEL [V]**
- **LEVEL [A]**
- **BIAS [V]**
- **BIAS [A]**

2) Press one of above soft keys to select the list sweep parameter.

3.8.3 3.8.3 Sweep parameter setup

Move the cursor to the table to perform the setup of each sweep parameter: **FREQ (HZ)**, **LMT**, **HIGH** and **LOW**. Use numeric keys on the front panel to input the data of test frequency/level/bias and high/low limit used to compare, as well as the selected primary/secondary use to compare. After setting, if some inputs are unnecessary, you can execute the function of "Delete line" in the soft key zone to delete the corresponding value.

In the bottom of the **LMT** zone, parameter A indicates that the primary parameters of the measurement result are used to compare with the high and low limits of the table. Parameter B indicates that the secondary parameters of the measurement result are used to compare with the high and low limits of the table. "---" means no compare. The soft key zone has corresponding items. Press the soft key **LMT A**, "A" will be displayed in the **LMT** zone. When press the soft key **LMT B**, "B" will be displayed in the **LMT** zone. While press the soft key **OFF**, data in LMT zone and the corresponding high and low limits will be cleared and be displayed as "---".

4 Chapter 4 [SYSTEM]

4.1 4.1 <SYSTEM SETUP>

Press [System] to enter into the <SYSTEM SETUP> page, shown as below.



On this page, Basic system setup items are displayed, such as brightness, theme, key sound, language, PASS word, file format, date, time.

4.1.1 4.1.1 BRIGHTNESS

The zone is used to control and display the LCD brightness of instrument.

Operation step of setting LCD brightness:

Move cursor to **BRIGHTNESS**. The following softkeys will be displayed.

- INCR +

The softkey is used to increase the brightness.

- DECR -

The softkey is used to decrease the brightness.

4.1.2 4.1.2 THEME

This zone is used to alter the display style.

Operation steps for theme

1) Move the cursor to theme, the following soft keys will be displayed.

- Royalblue
This soft key is used to Royalblue as the theme.
- Seagreen
This soft key is used to select Seagreen as the theme.
- Steelblue
This soft key is used to select Steelblue as the theme.

4.1.3 4.1.3 KEY SOUND

This zone is used to turn on/off the key sound.

Operation steps for key sound

- 2) Move the cursor to key sound, the following soft keys will be displayed.
 - ON
This soft key is used to turn on the key sound.
 - OFF
This soft key is used to turn off the key sound.

4.1.4 4.1.4 LANGUAGE

This zone is used to control and display the current language mode of the operating instrument.

Operation steps for setting language

- 3) Move the cursor to Language, the following soft keys will be displayed.
 - English
This soft key is used to select English as the operation language.
 - Chinese
This soft key is used to select Chinese as the operation language.

4.1.5 4.1.5 PASS WORD

This zone is used to display the password –protection mode.

Operation steps for setting the password

- 1) Move the cursor to Password, the following soft keys will be displayed.
 - **OFF**
This soft key is used to turn off the password protection mode.
 - **Hold SYSTEM**
This soft key is used to turn on the password protection function including file protection and starting up password.
 - **Hold FILE**
This soft key is used to protect user's file.
 - **MODIFY**
This soft key is used to modify the password. The operation steps are as follows: Press **MODIFY** to input a new password. After inputting, a prompt information will appear on the screen to prompt you to confirm the new password. Input the new password again till the modification finishes.

Note: The default password is 2876.

4.1.6 4.1.6 FILE FORMAT

This zone is used to alter the display mode of the file in the file management page.

Operation steps for file format

- 4) Move the cursor to FILE FORMAT, the following soft keys will be displayed.
 - Trs ID
This soft key is used to select trs Id as the display mode.
 - File Name
This soft key is used to select File Name as the display mode.
 - File Name & Trs ID
This soft key is used to select File Name & Trs ID as the display mode.

4.1.7 4.1.7 DATE

When moving to the DATE zone, user should input the value directly.

4.1.8 4.1.8 TIME

When moving to the TIME zone, user should input the value directly.

4.2 4.2 <TEST SETUP>

Press [**SYSTEM**] ,and then **TEST SETUP** to enter into the **<TEST SETUP>** page shown as below.

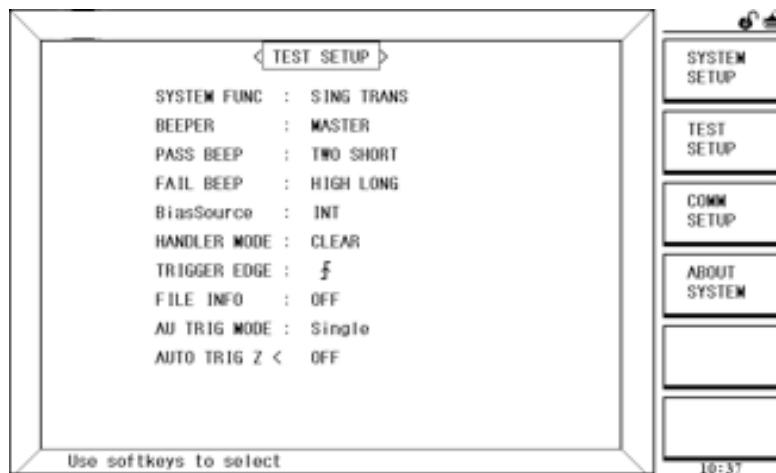

On this page, basic test setup items are displayed, such as system function, beeper, pass beeper, fail beeper, bias source, handler mode, trigger edge, file info., auto trig mode, auto trig z.

4.2.1 4.2.1 SYSTEM FUNC

The function of this zone is to control and display available instrument functions.

Operation steps for setting the instrument main function

1) Move the cursor to **SYSTEM FUNC**, the following soft keys will be displayed.

■ **TRANS SINGLE**

This soft key is used to select the transformer stand-alone test function.

■ **TRANS SCAN**

This soft key is used to select the transformer scanning test function.

4.2.2 4.2.2 BEEPER

This zone is used to control and display the beeper source.

Operation steps for selecting beeper

1) Move the cursor to **Beeper**, the following soft keys will be displayed.

■ **MASTER**

This soft key is used to select the instrument as the beeper source.

■ **SCANNER**

This soft key is used to select the scanner as the beeper source (available only when LM1050 connects a transformer scanning box).

■ **ALL**

This soft key is used to select both the instrument and the scanning box as the beeper source.

4.2.3 4.2.3 PASS BEEP

This zone is used to control the beep mode when the test result is qualified.

Operation steps for setting PASS BEEP

1) Move the cursor to ____, the following soft keys will be displayed.

■ **HIGH LONG**

This soft key is used to select high and long beep.

■ **HIGH SHORT**

This soft key is used to select high and short beep.

■ **LOW LONG**

This soft key is used to select low and long beep.

■ **TWO SHORT**

This soft key is used to select two low and short beeps.

■ **OFF**

This soft key is used to set the pass beep function OFF.

Note: In the scanning box, the potentiometer is used to adjust the volume, so when selecting SCANBOX as the beep source, you can only control the volume to be long and short but not high and low.

4.2.4 4.2.4 FAIL BEEP

This zone is used to control and display the beep mode as **FAIL BEEP** when the test result is unqualified.

Operation steps for setting FAIL BEEP

1) Move the cursor to FAIL beep, the following soft keys will be displayed.

■ **HIGH LONG**

This soft key is used to select high and long beep.

■ **HIGH SHORT**

This soft key is used to select high and short beep.

■ **LOW LONG**

This soft key is used to select low and short beep.

■ **TWO SHORT**

This soft key is used to select two low and short beeps.

■ **OFF**

This soft key is used to set the fail beep mode OFF.

Note: In scanning box, the potentiometer is used to adjust the volume, so when selecting SCANBOX as the beep source, you can only control the beep to be long and short but not high and low.

4.2.5 4.2.5 BiasSource

Bias source is used to select the DC bias power. The instrument provides 3 kinds of bias source as following:

- INT mode:
The standard DC bias source : 0V、1.5V、2V.
- OPT mode:
The optional DC bias source can provide inner DC bias source (0~100mA and inner DC bias voltage source (-10V~+10V).

Note: KA1022 optional must be installed, then the mode can be supported.

Note: when OPT bias board is selected, only 100 Ω output resistance is available.

- OPT1A mode:
The inner-installed optional DC bias source can provide DC bias source (0~1A)。
-

Note: KA1023 must be installed, then the mode can be supported.

- EXT mode:
The instrument uses external bias source to perform on-line test.

operation step of setting bias source:

- 1) Move cursor to **Bias Sourc**. The following softkeys can be displayed.
 - INT
 - OPT
 - EXT
- 2) Press **INT**, and select INT bias source.
- 3) Press **OPT**, and select OPT bias source or OPT1A.
- 4) Press **EXT**, and select EXT bias source.

4.2.6 4.2.6 HANDLER MODE

This mode is used to select HANDLER MODE.

Operation steps for setting handler mode

- 1) Move the cursor to **HANDLER MODE**, the following soft keys will be displayed.
 - CLEAR
 - HOLD
- 2) Use above soft keys to select the required handler mode.

4.2.7 4.2.7 TRIGGER EDGE

This mode is used to select trigger mode.

Operation steps for setting trigger edge

- (1) Move the cursor to **trigger edge**, the following soft keys will be displayed.
 - **Rising Edge**
while you press down the trigger key, then the instrument will measure the DUT.
 - **Falling Edge**
while you loosen the trigger key, then the instrument will measure the DUT.
- (2) Use above soft keys to select the required trigger edge.

4.2.8 4.2.8 FILE INFO

This zone is used to control the file information when saving the measuring data.
Operation steps for FILE INFO:

- 1) Move the cursor to **FILE INFO**, the following soft keys will be displayed.
 - OFF
This soft key is used to turn off the file information.
 - ON
This soft key is used to turn on the file information.

4.3 4.3 <INTERFACE SETUP>

Press **[SYSTEM]**, and then **COMM SETUP** to enter into the **<INTERFACE SETUP>** page shown as below.

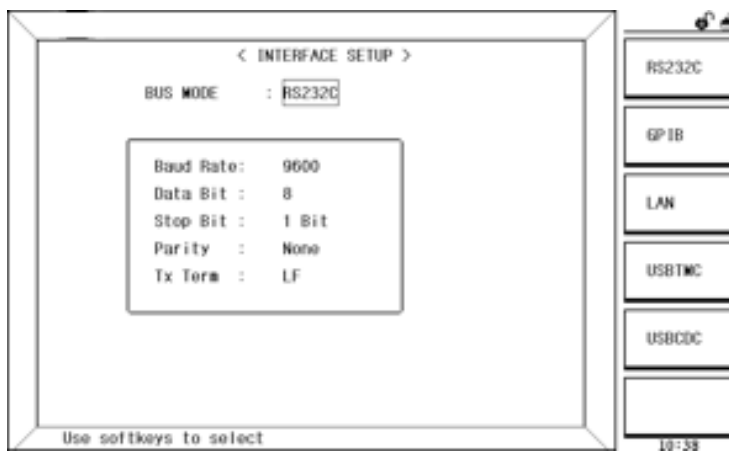

On this page, basic interface setup items are displayed, such as bus mode.

4.3.1 4.3.1 BUS MODE

This mode is used to select RS232C, GPIB, LAN, USBTMC or USBCDC.

Operation steps for setting bus mode

- 3) Move the cursor to **Bus**, the following soft keys will be displayed.
 - RS232C
 - GPIB
 - LAN
 - USBTMC
 - USBCDC
- 4) Use above soft keys to select the required interface bus.

Note: GPIB must be installed before GPIB mode is available.

4.3.2 4.3.2 BAUD RATE

Baud rate is used select the baud rate of the RS232C interface. The available baud rate of this instrument is from 9.600k to 115.200k.

Operation steps for setting the baud rate

- 1) Move the cursor to **BAUD RATE**, the following soft keys will be displayed.
 - ↑ (+)
This soft key is used to increase the baud rate.
 - ↓ (-)
This soft key is used to decrease the baud rate.

4.3.3 4.3.3 GPIB ADDR (Reserved function)

This zone is used to control and display the current GPIB address.

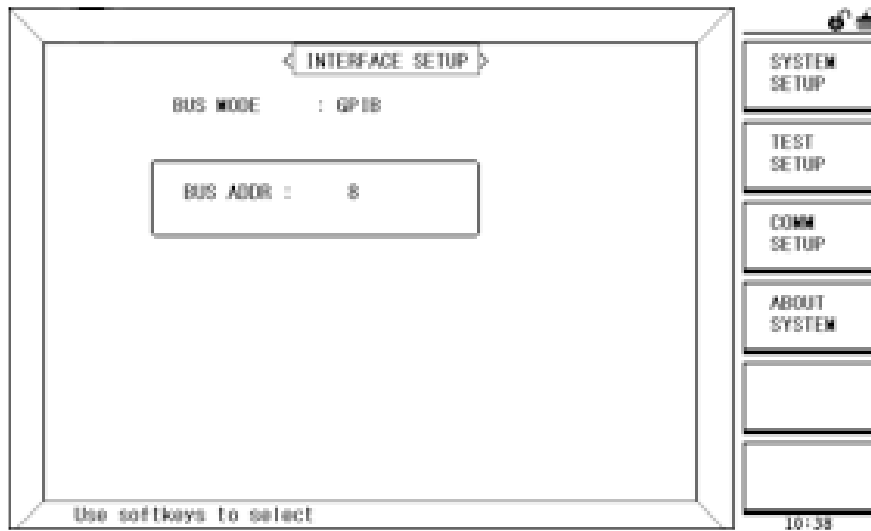

Operation steps for setting GPIB address:

Move the cursor to **GPIB ADDR**, the following soft keys will be displayed.

- ↑ (+)

This soft key is used to increase the GPIB address.

- ↓ (-)

This soft key is used to decrease the GPIB address.

4.4 4.4 <ABOUT SYSTEM>

Press **[SYSTEM]**, and then **ABOUT SYSTEM** to enter into the **<ABOUT SYSTEM>** page shown as below.

On this page, the basic content of the instrument is listed also this page allows to reset meter to the factory settings and to update instrument firmware.

5 Chapter 5 FILE MANAGE

5.1 5.1 <Files List>

LM1050 series instrument can save the user-set parameter to the nonvolatile memory in the form of file, so when use the same setting next time user can load a corresponding file to obtain the parameter set and used last time. By doing so, it can save the time of setting parameter and improve the production efficiency. The file manage function of the transformer scanning will be described in the part of transformer test setting.

Press [FILE] key to enter into the file manage page, shown as below.

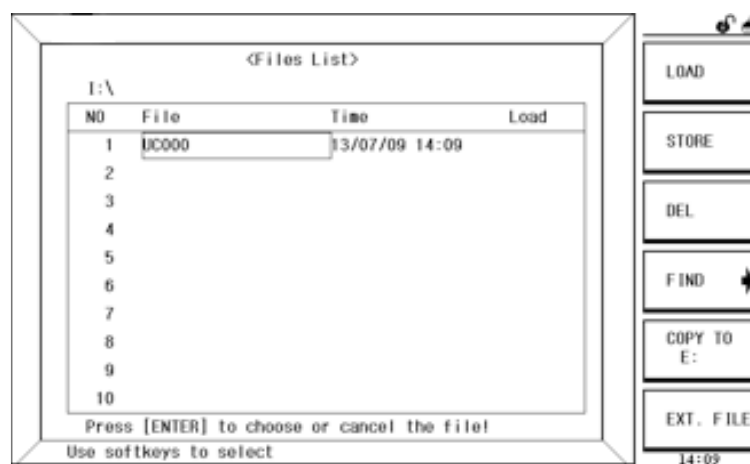

5.1.1 5.1.1 Setup file for single-group component (*.STA)

100 groups of different single groups of component set file (*.LCR file) can be saved in the instrument, but the *.LCR file with the number more than 100 should be saved in external U-disk (note: U-disk is an optional accessory). Press [FILE], the following data will be saved or loaded in the form of file, which are called *.LCR file.

5.1.2 5.1.2 U-disk manage performance

As described above, LM1050 has a standard configuration of USB HOST interface, so the external U-disk can be used as the memory media. In this condition, it breaks the memory limit of 100 groups of *.LCR files. Meanwhile those files can be copied to PC or compatible desk-top computer, laptop with USB interface to reach the infinite extension.

LM1050 supports the USB memory devices as below:

- Meet the USB 1.0/1.1 standard
- Capacity: 32MB/64MB/128MB/256MB/512MB/1G/2G/4G
- File format: FAT16/FAT32(Format the USB memory on Microsoft Windows operation system)

5.1.3 5.1.3 Operation steps for file management

A. Search an existed file

- 1) Use the [↑] and [↓] to view one by one.
- 2) Use the [←] and [→] to view one page by one page.
- 3) Press the soft key **FIND**. Input the file name and then press the [ENTER] to search the target file.
- 4) Input the file number and press [ENTER] to go to the position directly.

B. Save the following control and setting parameters to a file by the following steps

- 1) Select and set all control and setting parameters on the desired page.
- 2) Press [FILE] to enter into the <Files List> , the following soft keys will be displayed.
 - **LOAD**
 - **STORE**
 - **DEL**
 - **FIND**
 - **COPY TO E:**
 - **EXT**
- 3) In the file list, move the cursor to the file-saved position or input the file number directly.
- 4) Press **STORE**, the following soft keys will be displayed.
 - **Yes**
 - **No**
- 5) Press **No** to cancel the current save operation and return step 2.
- 6) Press **Yes**, and dialogue box of "Input the file name: " will displayed.
- 7) Use numeric keys to input the current file name and press [ENTER] to confirm. Then LM1050 will save the control and setting parameters as a file in this name.

C. Load the control and setting parameters from a file by the following steps

- 1) Press [FILE], the file list and the following soft keys will be displayed.
 - **LOAD**
 - **STORE**
 - **DEL**
 - **FIND**
 - **COPY to E:**
 - **EXT. FILE**
- 2) In the file list, move the cursor to the file-saved position or input the file number directly.
- 3) Press **LOAD**, the following soft keys will be displayed.
 - **Yes**
 - **No**
- 4) Press **No** to cancel the current load operation and return step 1.
- 5) Press **Yes** to load the currently selected file. Then LM1050 will return the current display page.

D. Copy a file to an U disk by the following steps

- 1) Assuming that it is necessary to copy internal files 2 and 3 to files 12 and 13 respectively.
- 2) Press [FILE], the file list and the following soft keys will be displayed.
 - **LOAD**
 - **STORE**
 - **DEL**
 - **FIND**
 - **COPY to E:**
 - **EXT**
- 3) Move the cursor the file to be copied and press [ENTER] to confirm.
- 4) Press **COPEY TO I:** to copy the file to the internal memory of the instrument.
- 5) Input object file No. and press [ENTER] key, the instrument will read and write files in U-disk automatically. You have to intern U-disk into USB interface.

NOTE: Please make sure that your U-disk meets the standard that described in this
chapter and no write-read protection.

6 Chapter 6 Performance and Test

6.1 6.1 Test function

6.1.1 6.1.1 Parameter and symbol

C: capacitance	L: Inductance	
R: resistance	Z: impedance	Y: Admittance
X: reactance	B: susceptance	G: Conductance
D: dissipation	θ : phase angle	Q: Quality factor
DCR: DC resistance		

6.1.2 6.1.2 Mathematical operation

Operation between the measurement value and the programmable nominal value: absolute deviation Δ ABS and percent deviation $\Delta\%$.

6.1.3 6.1.3 Equivalent mode

Series and parallel

6.1.4 6.1.4 Trigger

Internal, external and manual

Internal: Test DUT constantly and display the result

Manual: Press TRIGGER to test once then the result will be displayed.

External: After HANDLER receiving "start" signal, perform a measurement and output test result.

6.1.5 6.1.5 Delay time

Delay time: time from trigger to start. 0 to 60s are programmable with a resolution of 1ms.

6.1.6 6.1.6 Connection modes of test terminals

LM1050 adopts 4-terminal test method.

HD(Hcur): Current sample high terminal

LD(Lcur): Current sample low terminal

HS(Hpot) : Voltage sample high terminal

LS(Lpot): Voltage sample low terminal

6.1.7 6.1.7 Test speed (Frequency \geq 10kHz)

Fast: about 200 times

Medium: about 25 times

Slow: about 5 times

The fast and middle speed will be slow down when frequency <1 kHz.

6.1.8 6.1.8 Display digit

6 digits, max. displayed digit: 999999

6.2 6.2 Test signal**6.2.1 6.2.1 Test signal frequency**

Test signal is sine wave, accuracy: 0.02%

Frequency range:

20Hz~2MHz for LM1050A, resolution: 0.01Hz

20Hz~5MHz for LM1050B, resolution: 0.01Hz

6.2.2 6.2.2 Signal mode

Normal: When testing, on measurement display page, voltage across test terminals may be smaller than preset voltage.

Constant level: The auto adjustment of internal level makes the voltage of DUT accordant with preset voltage.

6.2.3 6.2.3 Test signal level

	Mode	Range	Accuracy	Resolution
Voltage	Normal constant level	5mV _{RMS} —5V _{RMS} 5mV _{RMS} —1V _{RMS}	$\pm (10\% \times \text{preset value} + 2\text{mV})$ $\pm (20\% \times \text{preset value} + 2\text{mV})$	1mV
Current	Normal constant current	50 μ A _{RMS} — 100mA _{RMS} 10 μ A _{RMS} — 20mA _{RMS}	$\pm (10\% \times \text{preset value} + 10\mu\text{A}_{\text{RMS}})$ $\pm (20\% \times \text{preset value} + 10\mu\text{A}_{\text{RMS}})$	1 μ A

6.2.4 6.2.4 Output impedance

10Ω/CC, 30Ω, 50Ω and 100Ω are selectable.

6.2.5 6.2.5 Monitor for test signal level

Mode	Range	Accuracy
Voltage	0V _{RMS} —5V _{RMS}	± (10%×reading+10mV)
Current	0A _{RMS} —100mA _{RMS}	± (10%×reading +10μA)

6.2.6 6.2.6 Maximum measurement display range

Parameter	Measurement display range
L、Lk	0.00001μH ~ 99.9999kH
C	0.00001pF ~ 9.99999F
Z、R、X、DCR	0.00001Ω~ 99.9999MΩ
Y、B、G	0.00001μs ~ 99.9999S
D	0.00001 — 9.99999
Q	0.00001 — 99999.9
θ	Deg -179.999°~179.999° Rad -3.14159 ~ 3.14159

6.2.7 6.2.7 DC resistance test voltage

1.4VDC (test terminal is open)

accuracy: ±5%

internal resistance: 50Ω±5%

6.2.8 6.2.8 Internal DC voltage bias

-5v~+5V, ±(10%+10mV), 1mV by stepper

6.3 6.3 Measurement accuracy

The relation of test accuracy and basic accuracy is shown as below :

Test accuracy = (Basic accuracy)×C×D+E

C : Speed factor

D : Cable length factor

E : Temperature factor

6.3.1 Basic accuracy

Basic accuracy is calculated by A, B in basic accuracy factor table.

Note:

(1) when frequency is larger than 1.001MHz, basic accuracy must multiply (f(MHz)+3)/4;

(2) In the mode of constant voltage or current

When range >= 100Ω

$$\text{Basic accuracy } Z(\%) \text{ or } \theta(^{\circ}) = \pm \left(A + \frac{B * |Zx[\Omega] - Range[\Omega]|}{Range[\Omega]} \right) \quad (2)$$

When range < 100 Ω

$$\text{Basic accuracy } Z(\%) \text{ or } \theta(^{\circ}) = \pm \left(A + \frac{B * |Range[\Omega] * 10 - Zx[\Omega]|}{Range[\Omega]} \right) \quad (3)$$

In (2)、(3),

Zx: sample value of |Z|

The sample value of impedance is considered as test result or calculated by the formula below:

$$\begin{aligned} |Zx| (\Omega) &= \omega L(H) & (\theta = 90^{\circ}) \\ &= 1/\omega C(F) & (\theta = -90^{\circ}) \\ &= R(\Omega) & (\theta = 0^{\circ}) \end{aligned}$$

Test condition of basic accuracy:

1. Use special test fixture;
2. Test speed: SLOW
3. Cable length factor: 0m
4. Temperature and humidity: 20±5° , (RH) <= 80%
5. Warm up: 60 Min
6. Before testing, perform open and short correction

6.3.2 Test speed factor(C)

Speed	(FAST)	(NORMAL)	(SLOW)
C	5	2	1

6.3.3 Cable length factor

Cable length	0m	1m
D	1	(100kHz max) 1.5+0.015*f[kHz]
		(100.1kHz min) 1.5+0.3*f[kHz]

6.3.4 6.3.4 Temperature factor

Temperature	Operation temperature=T°
E	0.1*basic accuracy*(T-20)

Basic accuracy table 1(0.010V to 0.049V)
When range >=100Ω

$$\text{Basic accuracy} = \pm(A + \frac{B * |Zx[\Omega] - \text{Range}[\Omega]|}{\text{Range}[\Omega]})$$

When range <100Ω

$$\text{Basic accuracy} = \pm(A + \frac{B * |\text{Range}[\Omega] * 10 - Zx[\Omega]|}{\text{Range}[\Omega]})$$

Zx: sample value of impedance Z

A,B: Basic accuracy factor

Accuracy factor of Z(%): value A, B in group 1

Accuracy factor of θ (°): value A, B in group 2

When $f \geq 1.001\text{MHz}$, basic accuracy must multiply (f[MHz]+3)/4.

Table 6-1 Basic accuracy 1(0.010V to 0.049V)

*1	Range	20Hz-99.9Hz	100Hz-1kHz	1.001kHz-10kHz	10.01kHz-100kHz	100.1kHz-1MHz	1.001MHz-5MHz
6month	1MΩ						
	100kΩ	A=1.5 B=1	A=1 B=0.5	A=1 B=0.5			
		A=2 B=0.3	A=0.5 B=0.1	A=0.5 B=0.1			
	10kΩ	A=0.8 B=0.5	A=0.5 B=0.2	A=0.5 B=0.2	A=1.5 B=0.5		
		A=0.5 B=0.01	A=0.2 B=0.02	A=0.2 B=0.02	A=0.6 B=0.05		
	3kΩ	A=0.8 B=0.5	A=0.5 B=0.2	A=0.5 B=0.2	A=1.5 B=0.5		
		A=0.5 B=0.01	A=0.2 B=0.02	A=0.2 B=0.02	A=0.6 B=0.05		
	1kΩ	A=0.6 B=0.05	A=0.25 B=0.01	A=0.25 B=0.01	A=1 B=0.2		
		A=0.5 B=0.01	A=0.15 B=0.01	A=0.15 B=0.01	A=0.5 B=0.02		
	300Ω	A=0.6 B=0.05	A=0.25 B=0.01	A=0.25 B=0.01	A=1 B=0.2		
		A=0.5 B=0.01	A=0.15 B=0.01	A=0.15 B=0.01	A=0.5 B=0.02		
	100Ω	A=0.6 B=0.05	A=0.25 B=0.01	A=0.25 B=0.02	A=0.5 B=0.02	A=2 B=0.5	
		A=0.5 B=0.01	A=0.15 B=0.02	A=0.15 B=0.01	A=0.5 B=0.02	A=2 B=0.5	
	30Ω	A=0.6 B=0.05	A=0.25 B=0.01	A=0.25 B=0.02	A=0.5 B=0.02	A=2 B=0.5	
		A=0.5 B=0.01	A=0.15 B=0.02	A=0.15 B=0.01	A=0.5 B=0.02	A=2 B=0.5	
	10Ω	A=0.6 B=0.05	A=0.25 B=0.02	A=0.25 B=0.02	A=0.5 B=0.02	A=2 B=0.5	
		A=0.5 B=0.02	A=0.15 B=0.02	A=0.15 B=0.02	A=0.5 B=0.02	A=2 B=0.5	
	1Ω	A=1 B=0.2	A=0.4 B=0.2	A=0.4 B=0.2	A=1 B=0.2	A=3 B=1	
		A=0.5 B=0.5	A=0.3 B=0.05	A=0.3 B=0.05	A=0.6 B=0.1	A=3 B=1	

*1	Range	20Hz-99.9Hz	100Hz-1kHz	1.001kHz-10kHz	10.01kHz-100kHz	100.1kHz-1MHz	1.001MHz-5MHz
1year	1MΩ						
	100kΩ	A=2.25 B=1.5	A=1.5 B=0.75	A=1.5 B=0.75			
		A=3 B=0.45	A=0.75 B=0.15	A=0.75 B=0.15			
	10kΩ	A=1.2 B=0.75	A=0.75 B=0.3	A=0.75 B=0.3	A=2.25 B=0.75		
		A=0.75 B=0.015	A=0.3 B=0.03	A=0.3 B=0.03	A=0.9 B=0.075		
	3kΩ	A=1.2 B=0.75	A=0.75 B=0.3	A=0.75 B=0.3	A=2.25 B=0.75		
		A=0.75 B=0.015	A=0.3 B=0.03	A=0.3 B=0.03	A=0.9 B=0.075		
	1kΩ	A=0.9 B=0.075	A=0.375 B=0.015	A=0.375 B=0.015	A=1.5 B=0.3		
		A=0.75 B=0.015	A=0.225 B=0.015	A=0.225 B=0.015	A=0.75 B=0.03		
	300Ω	A=0.9 B=0.075	A=0.375 B=0.015	A=0.375 B=0.015	A=1.5 B=0.3		
		A=0.75 B=0.015	A=0.225 B=0.015	A=0.225 B=0.015	A=0.75 B=0.03		
	100Ω	A=0.9 B=0.075	A=0.375 B=0.015	A=0.375 B=0.015	A=0.75 B=0.03	A=3 B=0.75	
		A=0.75 B=0.015	A=0.225 B=0.015	A=0.225 B=0.015	A=0.75 B=0.03	A=3 B=0.75	
	30Ω	A=0.9 B=0.075	A=0.375 B=0.015	A=0.375 B=0.015	A=0.75 B=0.03	A=3 B=0.75	
		A=0.75 B=0.015	A=0.225 B=0.015	A=0.225 B=0.015	A=0.75 B=0.03	A=3 B=0.75	
	10Ω	A=0.9 B=0.075	A=0.375 B=0.03	A=0.375 B=0.03	A=0.75 B=0.03	A=3 B=0.75	
		A=0.75 B=0.03	A=0.225 B=0.03	A=0.225 B=0.03	A=0.75 B=0.03	A=3 B=0.75	
	1Ω	A=1.5 B=0.3	A=0.6 B=0.3	A=0.6 B=0.3	A=1.5 B=0.3	A=4.5 B=1.5	
		A=0.75 B=0.75	A=0.45 B=0.075	A=0.45 B=0.075	A=0.9 B=0.15	A=4.5 B=1.5	

Basic accuracy table 2(0.050V to 0.100V)
When range >= 100Ω

$$\text{Basic accuracy} = \pm \left(A + \frac{B * |Zx[\Omega] - \text{Range}[\Omega]|}{\text{Range}[\Omega]} \right)$$

When range < 100Ω

$$\text{Basic accuracy} = \pm \left(A + \frac{B * |\text{Range}[\Omega] * 10 - Zx[\Omega]|}{\text{Range}[\Omega]} \right)$$

Zx: sample value of impedance Z

A,B: Basic accuracy factor

Accuracy factor of Z (%): value A, B in group 1

Accuracy factor of θ (°): value A, B in group 2

When $f \geq 1.001\text{MHz}$, basic accuracy must multiply $(f[\text{MHz}] + 3)/4$.

Table 6-2 Basic accuracy 2(0.050V to 0.100V)

*1	Range	20Hz-99.9Hz	100Hz-1kHz	1.001kHz-10kHz	10.01kHz-100kHz	100.1kHz-1MHz	1.001MHz-5MHz
6month	1MΩ						
	100kΩ	A=1 B=0.2	A=0.5 B=0.05	A=0.5 B=0.05	A=1 B=0.2		
		A=1.5 B=0.2	A=0.25 B=0.05	A=0.25 B=0.05	A=1 B=0.1		
	10kΩ	A=0.5 B=0.01	A=0.2 B=0.01	A=0.25 B=0.01	A=0.5 B=0.05	A=3.5 B=2	
		A=0.35 B=0.01	A=0.15 B=0.01	A=0.15 B=0.01	A=0.3 B=0.05	A=1.5 B=1	
	3kΩ	A=0.5 B=0.01	A=0.2 B=0.01	A=0.25 B=0.01	A=0.5 B=0.05	A=3.5 B=2	
		A=0.35 B=0.01	A=0.15 B=0.01	A=0.15 B=0.01	A=0.3 B=0.05	A=1.5 B=1	
	1kΩ	A=0.5 B=0.01	A=0.2 B=0.01	A=0.2 B=0.01	A=0.3 B=0.02	A=0.8 B=0.2	
		A=0.35 B=0.01	A=0.1 B=0.01	A=0.1 B=0.01	A=0.2 B=0.02	A=1 B=0.3	
	300Ω	A=0.5 B=0.01	A=0.2 B=0.01	A=0.2 B=0.01	A=0.3 B=0.02	A=0.8 B=0.2	
		A=0.35 B=0.01	A=0.1 B=0.01	A=0.1 B=0.01	A=0.2 B=0.02	A=1 B=0.3	
	100Ω	A=0.5 B=0.01	A=0.2 B=0.01	A=0.2 B=0.01	A=0.3 B=0.02	A=0.6 B=0.05	A=2.5 B=0.4
		A=0.35 B=0.01	A=0.15 B=0.01	A=0.1 B=0.01	A=0.2 B=0.02	A=0.4 B=0.05	A=2 B=0.2
	30Ω	A=0.5 B=0.01	A=0.2 B=0.01	A=0.2 B=0.01	A=0.3 B=0.02	A=0.6 B=0.05	A=2.5 B=0.4
		A=0.35 B=0.01	A=0.15 B=0.01	A=0.1 B=0.01	A=0.2 B=0.02	A=0.4 B=0.05	A=2 B=0.2
	10Ω	A=0.5 B=0.02	A=0.2 B=0.02	A=0.2 B=0.02	A=0.3 B=0.02	A=0.6 B=0.05	A=2.5 B=0.2
		A=0.35 B=0.02	A=0.1 B=0.02	A=0.1 B=0.02	A=0.2 B=0.02	A=0.4 B=0.05	A=2 B=0.2
	1Ω	A=0.6 B=0.1	A=0.35 B=0.04	A=0.35 B=0.04	A=0.35 B=0.04	A=1 B=0.5	A=4 B=1.5
		A=0.4 B=0.2	A=0.2 B=0.05	A=0.2 B=0.05	A=0.3 B=0.05	A=1 B=0.3	A=3.5 B=1
	*1	Range	20Hz-99.9Hz	100Hz-1kHz	1.001kHz-10kHz	10.01kHz-100kHz	100.1kHz-1MHz
1year	1MΩ						
	100kΩ	A=2.25 B=0.3	A=0.375 B=0.075	A=0.375 B=0.075	A=1.5 B=0.15		
		A=0.75 B=0.015	A=0.3 B=0.015	A=0.375 B=0.015	A=0.75 B=0.075	A=5.25 B=3	
	10kΩ	A=0.525 B=0.015	A=0.225 B=0.015	A=0.225 B=0.015	A=0.45 B=0.075	A=2.25 B=1.5	
		A=0.75 B=0.015	A=0.3 B=0.015	A=0.375 B=0.015	A=0.75 B=0.075	A=5.25 B=3	
	3kΩ	A=0.525 B=0.015	A=0.225 B=0.015	A=0.225 B=0.015	A=0.45 B=0.075	A=2.25 B=1.5	
		A=0.75 B=0.015	A=0.3 B=0.015	A=0.3 B=0.015	A=0.45 B=0.03	A=1.2 B=0.3	
	1kΩ	A=0.525 B=0.015	A=0.15 B=0.015	A=0.15 B=0.015	A=0.3 B=0.03	A=1.5 B=0.45	
		A=0.75 B=0.015	A=0.3 B=0.015	A=0.3 B=0.015	A=0.45 B=0.03	A=1.2 B=0.3	
	300Ω	A=0.525 B=0.015	A=0.15 B=0.015	A=0.15 B=0.015	A=0.3 B=0.03	A=1.5 B=0.45	
		A=0.75 B=0.015	A=0.3 B=0.015	A=0.3 B=0.015	A=0.45 B=0.03	A=0.9 B=0.075	A=3.75 B=0.6
	100Ω	A=0.525 B=0.015	A=0.15 B=0.015	A=0.15 B=0.015	A=0.3 B=0.03	A=0.6 B=0.075	A=3 B=0.3
		A=0.75 B=0.015	A=0.3 B=0.015	A=0.3 B=0.015	A=0.45 B=0.03	A=0.9 B=0.075	A=3.75 B=0.6
	30Ω	A=0.525 B=0.015	A=0.15 B=0.015	A=0.15 B=0.015	A=0.3 B=0.03	A=0.6 B=0.075	A=3 B=0.3
		A=0.5 B=0.02	A=0.2 B=0.02	A=0.2 B=0.02	A=0.3 B=0.02	A=0.6 B=0.05	A=2.5 B=0.2
	10Ω	A=0.35 B=0.02	A=0.1 B=0.02	A=0.1 B=0.02	A=0.2 B=0.02	A=0.4 B=0.05	A=2 B=0.2
		A=0.9 B=0.15	A=0.525 B=0.06	A=0.525 B=0.06	A=0.525 B=0.06	A=1.5 B=0.75	A=6 B=2.25
	1Ω	A=0.6 B=0.3	A=0.3 B=0.075	A=0.3 B=0.075	A=0.45 B=0.075	A=1.5 B=0.45	A=5.25 B=1.5
		A=0.4 B=0.2	A=0.2 B=0.05	A=0.2 B=0.05	A=0.3 B=0.05	A=1 B=0.3	A=3.5 B=1

Basic accuracy 3(0.101V to 0.500V)

When range $\geq 100\Omega$

$$\text{Basic accuracy} = \pm \left(A + \frac{B * |Zx[\Omega] - Range[\Omega]|}{Range[\Omega]} \right)$$

When range $< 100\Omega$

$$\text{Basic accuracy} = \pm \left(A + \frac{B * |Range[\Omega] * 10 - Zx[\Omega]|}{Range[\Omega]} \right)$$

Zx: sample value of impedance Z

A,B: basic accuracy factor

Accuracy factor of Z (%): value A, B in group 1

Accuracy factor of f (°): value A, B in group 2

When $f \geq 1.001\text{MHz}$, basic accuracy must multiply $(f[\text{MHz}] + 3)/4$.

Table 6-9 Basic accuracy 3(0.101V to 0.500V)

*1	Range	20Hz-99.9Hz	100Hz-1kHz	1.001kHz-10kHz	10.01kHz-100kHz	100.1kHz-1MHz	1.001MHz-5MHz
6month	1MΩ	A=1 B=1	A=0.7 B=0.5	A=0.7 B=0.5	A=1.2 B=1		
		A=2 B=0.2	A=0.3 B=0.2	A=0.3 B=0.2	A=1.2 B=0.5		
	100kΩ	A=0.45 B=0.05	A=0.3 B=0.05	A=0.3 B=0.05			
		A=0.35 B=0.2	A=0.2 B=0.02	A=0.2 B=0.02			
	10kΩ	A=0.4 B=0.01	A=0.15 B=0.01	A=0.2 B=0.01	A=0.3 B=0.04	A=2 B=1.5	
		A=0.3 B=0.01	A=0.008 B=0.01	A=0.1 B=0.01	A=0.25 B=0.03	A=1 B=0.5	
	3kΩ	A=0.4 B=0.01	A=0.15 B=0.01	A=0.2 B=0.01	A=0.3 B=0.04	A=2 B=1.5	
		A=0.3 B=0.01	A=0.008 B=0.01	A=0.1 B=0.01	A=0.25 B=0.03	A=1 B=0.5	
	1kΩ	A=0.4 B=0.01	A=0.15 B=0.01	A=0.15 B=0.01	A=0.25 B=0.02	A=0.5 B=0.05	A=2 B=1
		A=0.3 B=0.01	A=0.08 B=0.01	A=0.08 B=0.01	A=0.1 B=0.02	A=0.7 B=0.3	A=1.5 B=0.2
	300Ω	A=0.4 B=0.01	A=0.15 B=0.01	A=0.15 B=0.01	A=0.25 B=0.02	A=0.5 B=0.05	A=2 B=1
		A=0.3 B=0.01	A=0.08 B=0.01	A=0.08 B=0.01	A=0.1 B=0.02	A=0.7 B=0.3	A=1.5 B=0.2
	100Ω	A=0.4 B=0.02	A=0.15 B=0.02	A=0.15 B=0.01	A=0.25 B=0.02	A=0.5 B=0.03	A=2 B=0.2
		A=0.3 B=0.01	A=0.08 B=0.01	A=0.08 B=0.01	A=0.1 B=0.02	A=0.2 B=0.05	A=1.5 B=0.2
	30Ω	A=0.4 B=0.02	A=0.15 B=0.02	A=0.15 B=0.01	A=0.25 B=0.02	A=0.5 B=0.03	A=2 B=0.2
		A=0.3 B=0.01	A=0.08 B=0.01	A=0.08 B=0.01	A=0.1 B=0.02	A=0.2 B=0.05	A=1.5 B=0.2
	10Ω	A=0.4 B=0.02	A=0.15 B=0.02	A=0.15 B=0.02	A=0.25 B=0.02	A=0.5 B=0.03	A=2 B=0.2
		A=0.3 B=0.01	A=0.08 B=0.01	A=0.08 B=0.01	A=0.1 B=0.02	A=0.2 B=0.05	A=1.5 B=0.2
	1Ω	A=0.5 B=0.1	A=0.3 B=0.04	A=0.3 B=0.04	A=0.3 B=0.04	A=0.6 B=0.1	A=2.5 B=1.5
		A=0.35 B=0.2	A=0.15 B=0.03	A=0.15 B=0.03	A=0.2 B=0.03	A=0.6 B=0.1	A=3 B=1

*1	Range	20Hz-99.9Hz	100Hz-1kHz	1.001kHz-10kHz	10.01kHz-100kHz	100.1kHz-1MHz	1.001MHz-5MHz
1year	1MΩ	A=1.5 B=1.5	A=1.05 B=0.75	A=1.05 B=0.75	A=1.8 B=1.5		
		A=3 B=0.3	A=0.45 B=0.3	A=0.45 B=0.3	A=1.8 B=0.75		
	100kΩ	A=0.675 B=0.075	A=0.45 B=0.075	A=0.45 B=0.075	A=0.75 B=0.12		
		A=0.525 B=0.3	A=0.3 B=0.03	A=0.3 B=0.03	A=0.75 B=0.12		
	10kΩ	A=0.6 B=0.015	A=0.225 B=0.015	A=0.3 B=0.015	A=0.45 B=0.06	A=3 B=2.25	
		A=0.45 B=0.015	A=0.12 B=0.015	A=0.15 B=0.015	A=0.375 B=0.045	A=1.5 B=0.75	
	3kΩ	A=0.6 B=0.015	A=0.225 B=0.015	A=0.3 B=0.015	A=0.45 B=0.06	A=3 B=2.25	
		A=0.45 B=0.015	A=0.12 B=0.015	A=0.15 B=0.015	A=0.375 B=0.045	A=1.5 B=0.75	
	1kΩ	A=0.6 B=0.015	A=0.225 B=0.015	A=0.225 B=0.015	A=0.375 B=0.03	A=0.75 B=0.075	A=3 B=1.5
		A=0.45 B=0.015	A=0.12 B=0.015	A=0.12 B=0.015	A=0.15 B=0.03	A=1.05 B=0.45	A=2.25 B=0.75
	300Ω	A=0.6 B=0.015	A=0.225 B=0.015	A=0.225 B=0.015	A=0.375 B=0.03	A=0.75 B=0.075	A=3 B=1.5
		A=0.45 B=0.015	A=0.12 B=0.015	A=0.12 B=0.015	A=0.15 B=0.03	A=1.05 B=0.45	A=2.25 B=0.75
	100Ω	A=0.6 B=0.015	A=0.225 B=0.015	A=0.225 B=0.015	A=0.375 B=0.03	A=0.75 B=0.045	A=3 B=0.3
		A=0.45 B=0.015	A=0.12 B=0.015	A=0.12 B=0.015	A=0.15 B=0.03	A=0.3 B=0.075	A=2.25 B=0.3
	30Ω	A=0.6 B=0.015	A=0.225 B=0.015	A=0.225 B=0.015	A=0.375 B=0.03	A=0.75 B=0.045	A=3 B=0.3
		A=0.45 B=0.015	A=0.12 B=0.015	A=0.12 B=0.015	A=0.15 B=0.03	A=0.3 B=0.075	A=2.25 B=0.3
	10Ω	A=0.6 B=0.03	A=0.225 B=0.03	A=0.225 B=0.03	A=0.375 B=0.03	A=0.75 B=0.045	A=3 B=0.3
		A=0.45 B=0.015	A=0.12 B=0.015	A=0.12 B=0.015	A=0.15 B=0.03	A=0.3 B=0.075	A=2.25 B=0.3
	1Ω	A=0.75 B=0.15	A=0.45 B=0.06	A=0.45 B=0.06	A=0.45 B=0.06	A=0.9 B=0.15	A=3.75 B=2.25
		A=0.525 B=0.3	A=0.225 B=0.045	A=0.225 B=0.045	A=0.3 B=0.45	A=0.9 B=0.15	A=4.5 B=1.5

Basic accuracy 4(0.501V to 1.000V)

When range ≥ 100Ω

$$\text{Basic accuracy} = \pm \left(A + \frac{B * |Zx[\Omega] - Range[\Omega]|}{Range[\Omega]} \right)$$

When range < 100Ω

$$\text{Basic accuracy} = \pm \left(A + \frac{B * |Range[\Omega] * 10 - Zx[\Omega]|}{Range[\Omega]} \right)$$

Zx: sample value of impedance Z

A,B: basic accuracy factor

Accuracy factor of Z (%): value A, B in group 1

Accuracy factor of f (°): value A, B in group 2

When f ≥ 1.001MHz, basic accuracy must multiply (f[MHz]+3)/4.

Table 6-10 Basic accuracy 4(0.501V to 1.000V)

*1	Range	20Hz-99.9Hz	100Hz-1kHz	1.001kHz-10kHz	10.01kHz-100kHz	100.1kHz-1MHz	1.001MHz-5MHz
6month	1MΩ	A=0.8 B=0.4	A=0.4 B=0.2	A=0.4 B=0.2	A=0.4 B=0.5		
		A=1 B=0.2	A=0.25 B=0.1	A=0.25 B=0.1	A=1 B=0.5		
	100kΩ	A=0.4 B=0.05	A=0.15 B=0.05	A=0.15 B=0.05	A=0.3 B=0.08	A=3 B=1	
		A=0.3 B=0.1	A=0.15 B=0.02	A=0.15 B=0.02	A=0.3 B=0.08	A=3 B=0.5	
	10kΩ	A=0.35 B=0.01	A=0.08 B=0.01	A=0.15 B=0.01	A=0.25 B=0.04	A=0.4 B=0.3	A=2 B=0.5
		A=0.25 B=0.01	A=0.05 B=0.01	A=0.08 B=0.01	A=0.15 B=0.02	A=0.3 B=0.3	A=2 B=0.3
	3kΩ	A=0.35 B=0.01	A=0.08 B=0.01	A=0.15 B=0.01	A=0.25 B=0.04	A=0.4 B=0.3	A=2 B=0.5
		A=0.25 B=0.01	A=0.05 B=0.01	A=0.08 B=0.01	A=0.15 B=0.02	A=0.3 B=0.3	A=2 B=0.3
	1kΩ	A=0.35 B=0.01	A=0.08 B=0.01	A=0.08 B=0.01	A=0.2 B=0.02	A=0.3 B=0.03	A=1.5 B=0.2
		A=0.25 B=0.005	A=0.05 B=0.005	A=0.05 B=0.005	A=0.08 B=0.02	A=0.15 B=0.02	A=1 B=0.2
	300Ω	A=0.35 B=0.01	A=0.08 B=0.01	A=0.08 B=0.01	A=0.2 B=0.02	A=0.3 B=0.03	A=1.5 B=0.2
		A=0.25 B=0.005	A=0.05 B=0.005	A=0.05 B=0.005	A=0.08 B=0.02	A=0.15 B=0.02	A=1 B=0.2
	100Ω	A=0.35 B=0.01	A=0.08 B=0.01	A=0.08 B=0.01	A=0.2 B=0.02	A=0.3 B=0.03	A=1.5 B=0.2
		A=0.25 B=0.005	A=0.05 B=0.005	A=0.05 B=0.005	A=0.08 B=0.02	A=0.15 B=0.02	A=1 B=0.2
	30Ω	A=0.35 B=0.01	A=0.08 B=0.01	A=0.08 B=0.01	A=0.2 B=0.02	A=0.3 B=0.03	A=1.5 B=0.2
		A=0.25 B=0.005	A=0.05 B=0.005	A=0.05 B=0.005	A=0.08 B=0.02	A=0.15 B=0.02	A=1 B=0.2
	10Ω	A=0.35 B=0.02	A=0.08 B=0.02	A=0.08 B=0.02	A=0.2 B=0.02	A=0.3 B=0.03	A=1.5 B=0.2
		A=0.25 B=0.01	A=0.05 B=0.01	A=0.05 B=0.01	A=0.08 B=0.02	A=0.15 B=0.02	A=1 B=0.2
1Ω	A=0.4 B=0.04	A=0.2 B=0.03	A=0.2 B=0.03	A=0.2 B=0.03	A=0.4 B=0.1	A=2 B=1	
	A=0.3 B=0.1	A=0.1 B=0.02	A=0.1 B=0.02	A=0.15 B=0.02	A=0.3 B=0.05	A=2 B=0.5	
*1	Range	20Hz-99.9Hz	100Hz-1kHz	1.001kHz-10kHz	10.01kHz-100kHz	100.1kHz-1MHz	1.001MHz-5MHz
1year	1MΩ	A=1.2 B=0.6	A=0.6 B=0.3	A=0.6 B=0.3	A=1.5 B=0.75		
		A=1.5 B=0.3	A=0.375 B=0.15	A=0.375 B=0.15	A=1.5 B=0.75		
	100kΩ	A=0.6 B=0.075	A=0.225 B=0.075	A=0.225 B=0.075	A=0.45 B=0.12	A=4.5 B=1.5	
		A=0.45 B=0.15	A=0.225 B=0.03	A=0.225 B=0.03	A=0.45 B=0.12	A=4.5 B=0.75	
	10kΩ	A=0.525 B=0.015	A=0.12 B=0.015	A=0.225 B=0.015	A=0.375 B=0.06	A=0.6 B=0.45	A=3 B=0.75
		A=0.375 B=0.015	A=0.075 B=0.015	A=0.12 B=0.015	A=0.225 B=0.03	A=0.45 B=0.45	A=3 B=0.45
	3kΩ	A=0.525 B=0.015	A=0.12 B=0.015	A=0.225 B=0.015	A=0.375 B=0.06	A=0.6 B=0.45	A=3 B=0.75
		A=0.375 B=0.015	A=0.075 B=0.015	A=0.12 B=0.015	A=0.225 B=0.03	A=0.45 B=0.45	A=3 B=0.45
	1kΩ	A=0.525 B=0.015	A=0.12 B=0.015	A=0.12 B=0.015	A=0.3 B=0.03	A=0.45 B=0.045	A=2.25 B=0.3
		A=0.375 B=0.075	A=0.075 B=0.0075	A=0.075 B=0.0075	A=0.12 B=0.03	A=0.225 B=0.03	A=1.5 B=0.3
	300Ω	A=0.525 B=0.015	A=0.12 B=0.015	A=0.12 B=0.015	A=0.3 B=0.03	A=0.45 B=0.045	A=2.25 B=0.3
		A=0.375 B=0.075	A=0.075 B=0.0075	A=0.075 B=0.0075	A=0.12 B=0.03	A=0.225 B=0.03	A=1.5 B=0.3
	100Ω	A=0.525 B=0.015	A=0.12 B=0.015	A=0.12 B=0.015	A=0.3 B=0.03	A=0.45 B=0.045	A=2.25 B=0.3
		A=0.375 B=0.0075	A=0.075 B=0.0075	A=0.075 B=0.0075	A=0.12 B=0.03	A=0.225 B=0.03	A=1.5 B=0.3
	30Ω	A=0.525 B=0.015	A=0.12 B=0.015	A=0.12 B=0.015	A=0.3 B=0.03	A=0.45 B=0.045	A=2.25 B=0.3
		A=0.375 B=0.0075	A=0.075 B=0.0075	A=0.075 B=0.0075	A=0.12 B=0.03	A=0.225 B=0.03	A=1.5 B=0.3
	10Ω	A=0.525 B=0.03	A=0.12 B=0.03	A=0.12 B=0.03	A=0.3 B=0.03	A=0.45 B=0.045	A=2.25 B=0.3
		A=0.375 B=0.015	A=0.075 B=0.015	A=0.075 B=0.015	A=0.12 B=0.03	A=0.225 B=0.03	A=1.5 B=0.3
1Ω	A=0.6 B=0.06	A=0.3 B=0.045	A=0.3 B=0.045	A=0.3 B=0.045	A=0.6 B=0.15	A=3 B=1.5	
	A=0.45 B=0.15	A=0.15 B=0.03	A=0.15 B=0.03	A=0.225 B=0.03	A=0.45 B=0.075	A=3 B=0.75	

Basic accuracy 5(1.001V to 5.000V)

When range >= 100Ω

$$\text{Basic accuracy} = \pm \left(A + \frac{B * |Zx[\Omega] - \text{Range}[\Omega]|}{\text{Range}[\Omega]} \right)$$

When range < 100Ω

$$\text{Basic accuracy} = \pm \left(A + \frac{B * |\text{Range}[\Omega] * 10 - Zx[\Omega]|}{\text{Range}[\Omega]} \right)$$

Zx: sample value of impedance Z

A,B: basic accuracy factor

Accuracy factor of Z (%): value A, B in group 1

Accuracy factor of f (°): value A, B in group 2

When f >= 1.001MHz, basic accuracy must multiply (f[MHz]+3)/4.

Table 6-11 Basic accuracy 45(1.001V to 5.000V)

*1	Range	20Hz-99.9Hz	100Hz-1kHz	1.001kHz-10kHz	10.01kHz-100kHz	100.1kHz-1MHz	1.001MHz-5MHz
6month	1MΩ	A=1 B=0.4	A=0.5 B=0.2	A=0.5 B=0.2	A=1.2 B=0.5		
		A=2 B=0.3	A=0.3 B=0.1	A=0.3 B=0.1	A=1.2 B=0.5		
	100kΩ	A=0.5 B=0.1	A=0.2 B=0.05	A=0.2 B=0.05	A=0.5 B=0.08	A=3.2 B=1	
		A=0.4 B=0.2	A=0.2 B=0.02	A=0.2 B=0.02	A=0.5 B=0.08	A=3.2 B=0.5	
	10kΩ	A=0.4 B=0.01	A=0.15 B=0.01	A=0.2 B=0.01	A=0.3 B=0.04	A=1 B=0.3	
		A=0.3 B=0.02	A=0.08 B=0.01	A=0.1 B=0.01	A=0.2 B=0.03	A=0.5 B=0.3	
	3kΩ	A=0.4 B=0.01	A=0.15 B=0.01	A=0.2 B=0.01	A=0.3 B=0.04	A=1 B=0.3	
		A=0.3 B=0.02	A=0.08 B=0.01	A=0.1 B=0.01	A=0.2 B=0.03	A=0.5 B=0.3	
	1kΩ	A=0.4 B=0.01	A=0.15 B=0.01	A=0.15 B=0.01	A=0.25 B=0.02	A=0.7 B=0.05	
		A=0.3 B=0.01	A=0.08 B=0.01	A=0.08 B=0.01	A=0.1 B=0.02	A=0.2 B=0.02	
	300Ω	A=0.4 B=0.01	A=0.15 B=0.01	A=0.15 B=0.01	A=0.25 B=0.02	A=0.7 B=0.05	
		A=0.3 B=0.01	A=0.08 B=0.01	A=0.08 B=0.01	A=0.1 B=0.02	A=0.2 B=0.02	
	100Ω	A=0.4 B=0.01	A=0.15 B=0.01	A=0.15 B=0.01	A=0.25 B=0.02	A=0.5 B=0.05	
		A=0.3 B=0.01	A=0.08 B=0.01	A=0.08 B=0.01	A=0.1 B=0.02	A=0.2 B=0.02	
	30Ω	A=0.4 B=0.01	A=0.15 B=0.01	A=0.15 B=0.01	A=0.25 B=0.02	A=0.5 B=0.05	
		A=0.3 B=0.01	A=0.08 B=0.01	A=0.08 B=0.01	A=0.1 B=0.02	A=0.2 B=0.02	
	10Ω	A=0.4 B=0.02	A=0.15 B=0.02	A=0.15 B=0.02	A=0.25 B=0.02	A=0.5 B=0.05	
		A=0.3 B=0.01	A=0.08 B=0.01	A=0.08 B=0.01	A=0.1 B=0.02	A=0.2 B=0.02	
	1Ω	A=0.5 B=0.04	A=0.25 B=0.04	A=0.25 B=0.04	A=0.25 B=0.04	A=0.7 B=0.1	
		A=0.35 B=0.2	A=0.15 B=0.02	A=0.15 B=0.02	A=0.2 B=0.02	A=0.4 B=0.05	

*1	Range	20Hz-99.9Hz	100Hz-1kHz	1.001kHz-10kHz	10.01kHz-100kHz	100.1kHz-1MHz	1.001MHz-5MHz
1year	1MΩ	A=1.5 B=0.6	A=0.75 B=0.3	A=0.75 B=0.3	A=1.8 B=0.75		
		A=3 B=0.45	A=0.45 B=0.15	A=0.45 B=0.15	A=1.8 B=0.75		
	100kΩ	A=0.75 B=0.15	A=0.3 B=0.075	A=0.3 B=0.075	A=0.75 B=0.12	A=4.8 B=1.5	
		A=0.6 B=0.3	A=0.3 B=0.03	A=0.3 B=0.03	A=0.75 B=0.12	A=4.8 B=0.75	
	10kΩ	A=0.6 B=0.015	A=0.225 B=0.015	A=0.3 B=0.015	A=0.45 B=0.06	A=1.5 B=0.45	
		A=0.45 B=0.03	A=0.12 B=0.015	A=0.15 B=0.015	A=0.3 B=0.045	A=0.75 B=0.45	
	3kΩ	A=0.6 B=0.015	A=0.225 B=0.015	A=0.3 B=0.015	A=0.45 B=0.06	A=1.5 B=0.45	
		A=0.45 B=0.03	A=0.12 B=0.015	A=0.15 B=0.015	A=0.3 B=0.045	A=0.75 B=0.45	
	1kΩ	A=0.6 B=0.015	A=0.225 B=0.015	A=0.225 B=0.015	A=0.375 B=0.03	A=1.05 B=0.075	
		A=0.45 B=0.015	A=0.12 B=0.015	A=0.12 B=0.015	A=0.15 B=0.03	A=0.3 B=0.03	
	300Ω	A=0.6 B=0.015	A=0.225 B=0.015	A=0.225 B=0.015	A=0.375 B=0.03	A=0.75 B=0.075	
		A=0.45 B=0.015	A=0.12 B=0.015	A=0.12 B=0.015	A=0.15 B=0.03	A=0.3 B=0.03	
	100Ω	A=0.6 B=0.015	A=0.225 B=0.015	A=0.225 B=0.015	A=0.375 B=0.03	A=0.75 B=0.075	
		A=0.45 B=0.015	A=0.12 B=0.015	A=0.12 B=0.015	A=0.15 B=0.03	A=0.3 B=0.03	
	30Ω	A=0.6 B=0.015	A=0.225 B=0.015	A=0.225 B=0.015	A=0.375 B=0.03	A=0.75 B=0.075	
		A=0.45 B=0.015	A=0.12 B=0.015	A=0.12 B=0.015	A=0.15 B=0.03	A=0.3 B=0.03	
	10Ω	A=0.6 B=0.03	A=0.225 B=0.03	A=0.225 B=0.03	A=0.375 B=0.03	A=0.75 B=0.075	
		A=0.45 B=0.015	A=0.12 B=0.015	A=0.12 B=0.015	A=0.15 B=0.03	A=0.3 B=0.03	
	1Ω	A=0.75 B=0.06	A=0.375 B=0.06	A=0.375 B=0.06	A=0.375 B=0.06	A=1.05 B=0.15	
		A=0.525 B=0.3	A=0.225 B=0.03	A=0.225 B=0.03	A=0.3 B=0.03	A=0.6 B=0.075	

6.4 6.4 Safety requirement

6.4.1 6.4.1 insulation resistance

Referring to the working condition, the insulation resistance of the power terminal and the case should not be less than $50M\Omega$.

Under the damp and heat condition, the insulation resistance should not be less than $2 M\Omega$.

6.4.2 6.4.2 insulation intension

Referring the working condition, the power terminal and the case should can load the AC voltage with 50Hz in frequency and 1.5kV in rated voltage for 1 minute, and should have no breakdown and arcing.

6.4.3 6.4.3 Leakage current

The leakage current should not be more than 3.5mA (the AC effective value).

6.5 6.5 The EMC requirement

The transient sensitivity of the instrument power meets the GB6833.4.

The conduction sensitivity of the instrument meets the GB6833.6.

The radiated interference of the instrument meets the GB6833.10.

6.6 6.6 Performance test

6.6.1 6.6.1 Working condition

The test should be done referring to the condition described in chapter 1. we test the main performance. The other performance (e.g.: the parameter of the transformer) can be tested by yourself referring to the condition described in chapter 1.

6.6.2 6.6.2 The experiment instruments

The experiment instruments are shown in table 6-10

NO	The instrument name	requirement	
1	Standard capacitance	100pF	0.02% (the loss D has been known)
		1000pF	
		10000pF	
		10nF	
		0.1uF	
		1uF	
2	AC standard resistor	10Ω	0.02%
		100Ω	
		1kΩ	
		10kΩ	
		100kΩ	
3	DC standard resistor	0.1Ω	0.02%
		1Ω	
		10Ω	
		100Ω	
		1kΩ	
		10kΩ	
		100kΩ	
4	Standard capacitance	100μH	0.02%
		1mH	
		10mH	
		100mH	
5	Frequency meter	(0~1000) MHz	
6	digital multimeter	0.5%	
7	Insulation resistance meter	500V 10 levels	
8	withstanding voltage and leakage meter	0.25kW (0~500) V	

6.6.3 6.6.3 Check the Function

The keys, the display and the terminals can work normally. The other functions are right.

6.6.4 6.6.4 The test signal level

When the test signal level is tested, the digital multimeter is used. Adjust the range of the multimeter to AC, connect one test stick to the HCUR terminal of the instrument, and the other to the ground terminal. Change the level to 20mv, 100mv, 200mv, 1V and 2 V in turn, the test result must meet the requirement described in this chapter.

6.6.5 6.6.5 Frequency

Connect the ground terminal of the frequency meter to that of the instrument, and the test terminal of the frequency meter to the HCUR terminal of the instrument. Change the frequency to 20Hz, 100Hz, 1kHz, 10kHz, 100kHz and 200kHz in turn. The test result must meet the requirement described in this chapter.

6.6.6 6.6.6 The test accuracy

The main test parameters: R, L, C, D. the other parameters can be acquired from the parameters above.

6.6.7 6.6.7 The capacitance C and the loss D accuracy

function: Cp-D
the test frequency: 100Hz ,1kHz ,10kHz,100kHz
level: 1V
range: AUTO
bias: 0V
speed: slow

Short correction and open correction should be done before the test. Connect the standard capacitance (100pF, 1000pF, 10000pF, 10nF, 10nF, 0.1uF and 1uF) to the test fixture. Change the test frequency. The capacitance error between the test result and the standard value must be in the range of the C accuracy. The error of the loss D must be in the range of the D accuracy referring to this chapter.

6.6.8 6.6.8 The inductance L accuracy

Test condition:
Function: Ls-Q
Test frequency: 100Hz , 1kHz ,10kHz and 100kHz
Level: 1V
Range: AUTO
Bias: 0V
Speed: slow

Short correction and open correction should be done before the test. Connect the standard inductance (100μH, 1mH, 10mH and 100mH) to the test fixture. Change the test frequency. The error between the test result and the standard value must be in the range of the L accuracy referring to this chapter.

6.6.9 6.6.9 The resistance Z accuracy

Test condition:
Function: Z-θ
Test frequency: 100Hz, 1kHz ,10kHz and 100kHz
Level: 1V
Range: AUTO
Bias: 0V
Speed: slow

Short correction and open correction should be done before the test. Connect the standard resistor (10Ω, 100Ω, 1kΩ, 10kΩ, and 100kΩ) to the test fixture. Change the test frequency. The error between the test result and the standard value must be in the range of the |Z| accuracy referring to this chapter.

6.6.10 **6.6.10The DCR accuracy**

Test condition:

Function: DCR

Test frequency: -----

Level: -----

Range: AUTO

Bias: -----

Speed: slow

Short correction and open correction should be done before the test. Connect the standard resistor (0.1 Ω , 1 Ω , 10 Ω , 100 Ω , 1k Ω , 10k Ω , and 100k Ω) to the test fixture. The error between the test result and the standard value must be in the range of the DCR accuracy referring to this chapter.

7 Chapter 7 The description for Handler

This chapter will show you the Handler interface On LM1050.

The LM1050 provides the Handler interface for you. The interface is mainly used for the output of the sorted result. The interface offers the communication signal and the signal for the output of the sorted result. The separator result is corresponding to the output of BIN 10. The design for the Handler interface is very smart with the status of the output signal can be defined according to your application target.

7.1 7.1 The technology description for LM1050 Handler

Table 7-1 shows the description for LM1050 HANDLER.

Table 7-1 the HANDLER description

The output signal: low effective, open collector output, optoelectronic isolation	
Output signal judgment:	
BIN comparator: good, over the standard, not good list sweep comparator: IN/OUT for every sweep point and pass/fail for all the compared result.	
INDEX:	ADC ended
EOC:	end of one test and comparison
Alarm:	alarm for circuit interruption
The input signal:	optoelectronic isolation
Keylock:	lock the keys on the front panel
External Trigger:	pulsewidth $\geq 1\mu\text{S}$

7.2 7.2 The operation description

7.2.1 7.2.1 The definition for the signal line

The Handler interface has 3 signal: comparison output, control output and control input. The signal line's definition for the BIN comparison and list sweep comparison is below:

- Comparison signal lines:
 - Comparison output signal
/BIN1 - /BIN9, /AUX , /OUT, /PHI(the main parameter is higher), /PLO(the main parameter is lower), /SREJ(the secondary parameter is not good). The signal line distribution for comparison out is shown in figure 7-1.
 - Control output signal
/INDEX(analog test finished signal), /EOM(test ended and the compared data effective), /ALARM(the circuit interruption)
 - Control input signal
/EXT.TRIG(external trigger signal) , /Keylock(the key lock).

The signal distribution for the pins is described in table 7-2.

Table 7-2 The signal distribution for the pins

pin	signal name	description
1 2 3 4 5 6 7 8 9 10 11	/BIN1 /BIN2 /BIN3 /BIN4 /BIN5 /BIN6 /BIN7 /BIN8 /BIN9 /OUT /AUX	BIN sorted result /BIN(BIN number) output are all open collector output.
12 12	/EXT.TRIG	External trigger: when the trigger mode is EXT.TRIG, LM1050 will be triggered by the positive-edge in this pin.
14 15	EXT.DCV2	External DC voltage 2: The DC provider pin for the optoelectronic coupling signal(/EXT_TRIG, /KeyLock, /ALARM, /INDEX, /EOM)
16 17 18	+5V	The internal power +5V: to use the internal power is not recommended. If you use the internal power, please ensure that the current is lower than 0.3A and the signal line is far from the disturbance source.
19	/PHI	The main parameter is higher: the test result is greater than the high limit in BIN1 to BIN9.
20	/PLO	The main parameter is lower: the test result is less than the low limit in BIN1 to BIN9.
21	/SREJ	The secondary parameter is not good: the test result is not in the range of the high limit and the low limit.
22 23 24	NC NC NC	Not connect.
25	/KEY LOCK	When this single is effective, the keys in the front panel are locked.
27 28	EXT.DCV1	The external DC voltage 1: the pull-up DC power provider pin for optoelectronic coupling signal(/BIN-/BIN9,/AUX, /OUT, /PHI, /PLO, /SREJ).
29	/ALARM	When circuit is interrupted, /ALARM is effective.
30	/INDEX	When the analog test is finished and the UNKNOWN terminal can be connected to another DUT, /INDEX is effective. But the comparison signal is effective until /EOM is effective.
31	/EOM	End Of Measurement: when the test data and the compared result are effective, this signal is effective.
32, 33	COM2	The reference ground for external power EXTV2
34, 35, 36	COM1	The reference ground for external power EXTV1.

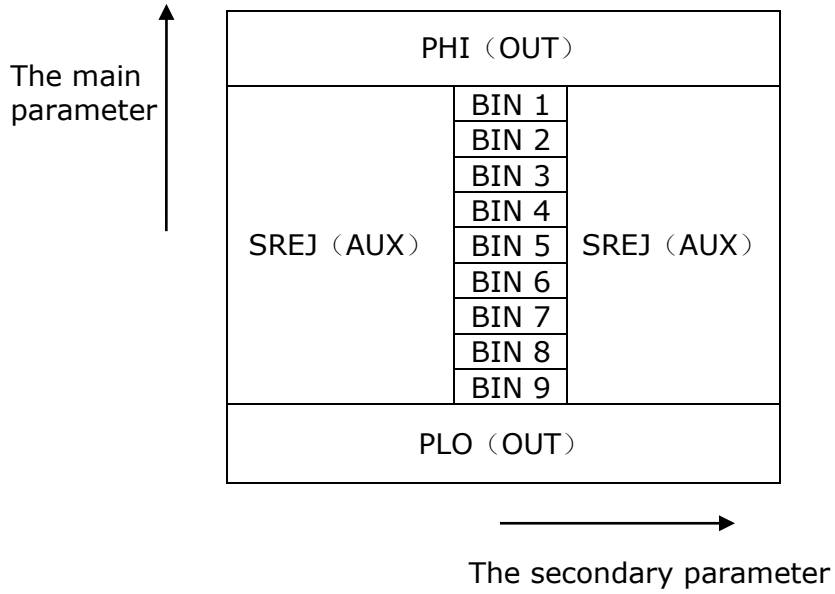
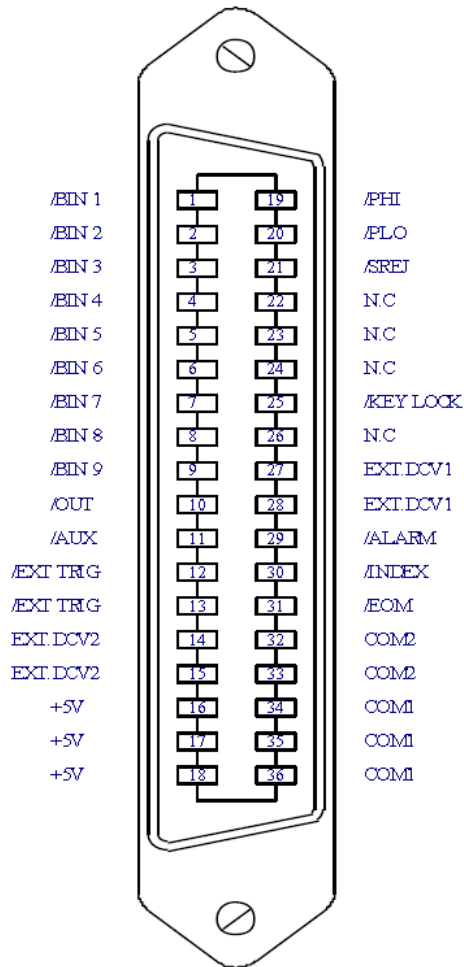
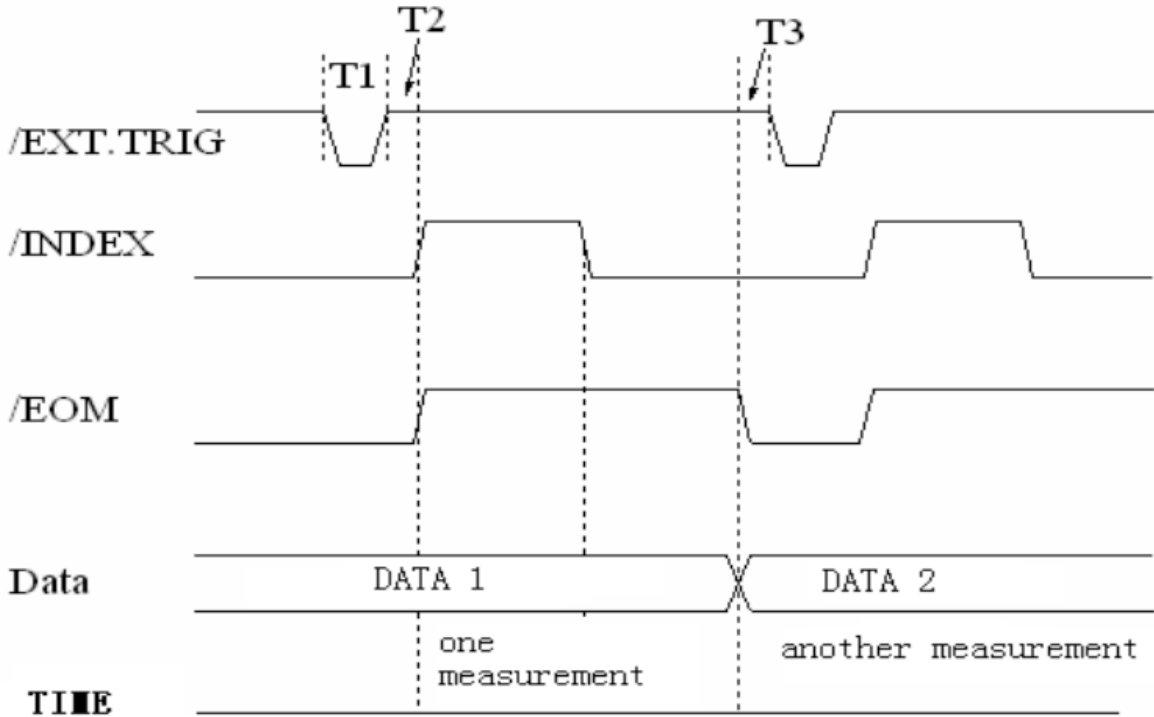

Figure 7-1 the /PHI, /PLO, /SREJ signal distribution for BIN comparison



Note: the signal to /BIN1 - /BIN9, /OUT, /AUX, /PHI, /PLO and /SREJ in the list sweep comparison is different from that in the BIN comparison.

Figure 7-2 the pin definition for HANDLER



time	The minimum	the maximum
T1: trigger pulse-width	1us	---
T2: delay time	200us	Display time ₃ + 200us
T3: the trigger waiting time after /EOM output	0us	---

1. for the measurement time, please refer to the operation manual;
2. the typical comparison time is approximately 1ms;
3. the display time for every display page is below:
 - MEAS DISPLAY: 8ms;
 - BIN NO.DISPLAY: 5ms;
 - BIN COUNT DISPLAY: 0.5ms

Figure 7-3 the timing chart

List sweep comparison signal line

The definition for list sweep comparison is different from that for the BIN comparison.

- Comparison output signal
/BIN-/BIN9 and /OUT show the IN/OUT (good or over the standard) judgment (figure 9-4). /AUX shows PASS/FAIL judgment. When a sweep test is finished, these signal will be the output signal.
- Control
/INDEX(analog test finished), /EOM(the test ended). The timing is below when /INDEX and /EOM are effective:

SEQ sweep mode:

/INDEX is defined as the effective signal when the last sweep point of the analog test is finished.

/EOM is defined as the effective signal when all the test results are effective after every list sweep task is finished.

STEP sweep mode:

/INDEX is defined as the effective signal when the analog test of every sweep point is finished.

/EOM is defined as the effective signal when the test and the comparison of every step are finished.

The pin distribution for list sweep is shown in table 7-3 and figure 7-2. (the pin definition for the list sweep comparison is the same to that for the BIN comparison). The timing chart is shown in figure 7-5.

Table 7-3 the pin distribute for the list sweep comparison

pin	signal	description
1	/BIN1	out of the limit of sweep point1
2	/BIN2	out of the limit of sweep point2
3	/BIN3	out of the limit of sweep point3
4	/BIN4	out of the limit of sweep point4
5	/BIN5	out of the limit of sweep point5
6	/BIN6	out of the limit of sweep point6
7	/BIN7	out of the limit of sweep point7
8	/BIN8	out of the limit of sweep point8
9	/BIN9	out of the limit of sweep point9
1	/OUT	out of the limit of sweep point10
0		
1	/AUX	/AUX is defined as the effective signal when at least one is not good in the list.
1		
3	/INDEX	SEQ: When the analog test of the last sweep point is finished and the UNKNOWN terminal can be connected to another DUT, /INDEX is effective. But the comparison signal is effective until /EOM is effective. STEP: When the analog test of the last sweep point is finished, /INDEX is effective. But the comparison signal is effective until /EOM is effective.
0		
3	/EOM	Test ended: SEQ: when the test is finished and the compared results are effective, this signal is effective. STEP: When the test of every sweep point is finished, /EOM is finished. the comparison result signal is effective until /EOM is effective.
1		
other		The definition is the same to that of the comparison.

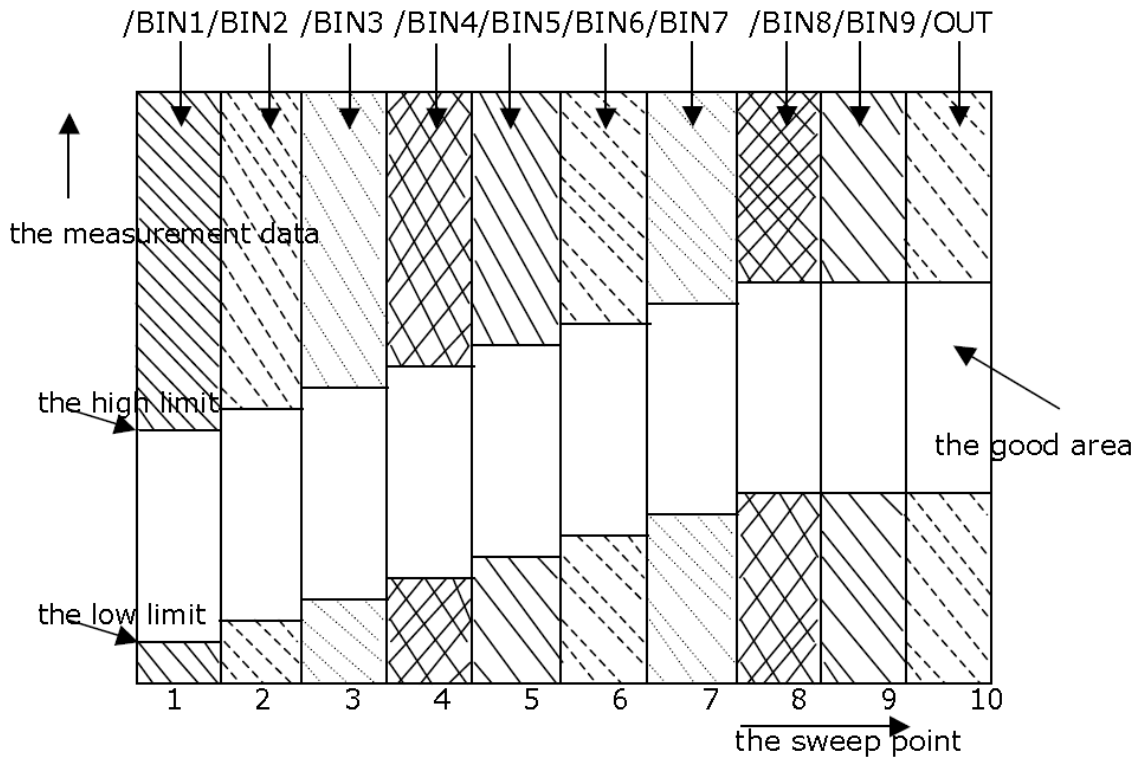

Figure 7-4 the signal area of the list sweep comparison

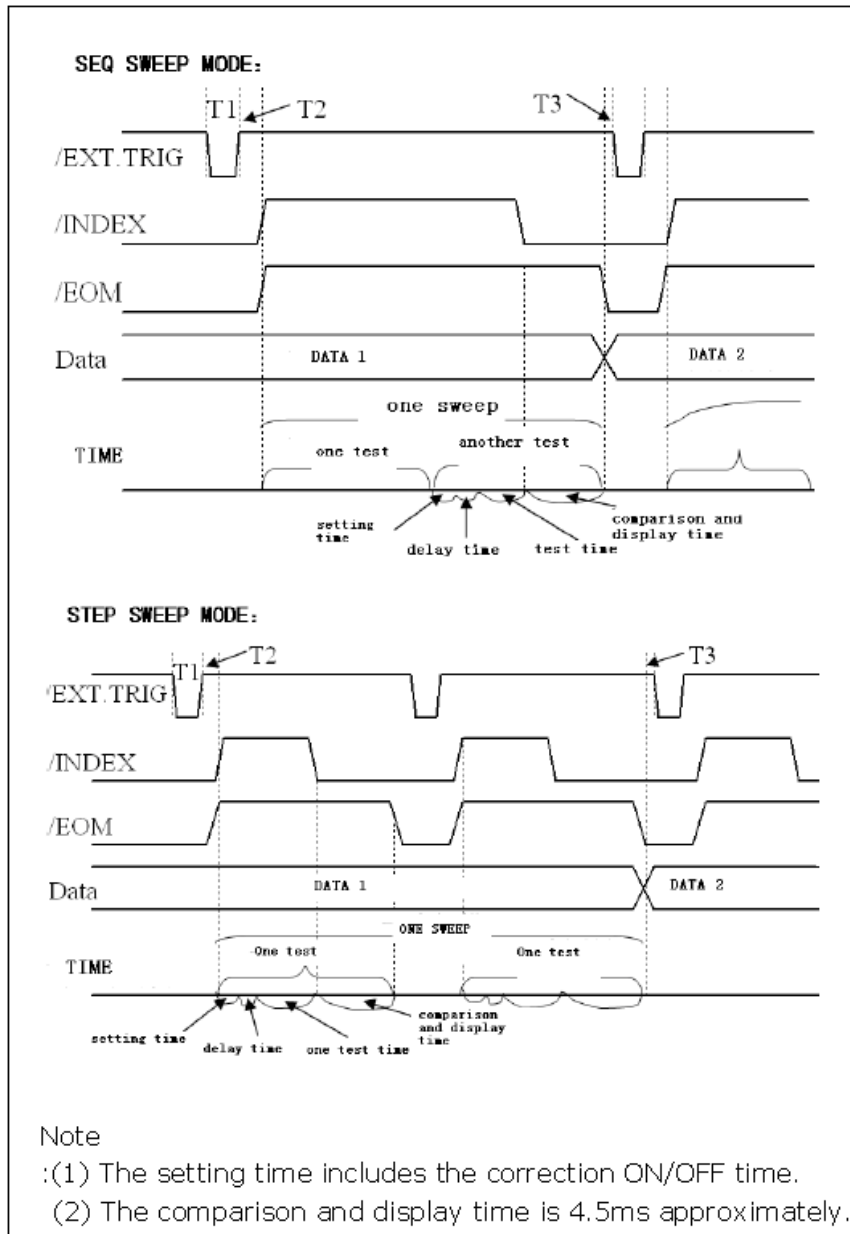

Figure 7-5 the time counting

7.2.2 7.2.2 Electrical feature

As it is shown above, the signal definition for the comparison and the list sweep comparison are different. But the electrical feature is same. So the description can be applied to BIN comparison and list sweep comparison.

DC isolation output: the DC isolation output (pin1 to pin16) generates the isolation by the optoelectronic coupler with the collector open. The output voltage on every line is set by the pull-up resistance on the HANDLER interface board. The pull-up resistance is connected to the internal voltage (+5v). or the external voltage(EXTV:+5v).

The electrical feature of the DC isolation output can be divided into 2 types shown in Table 7-4.

Table 7-4 the electrical feature of the DC isolation output

the output signal	the output rated voltage		the maximum current	the reference ground for the circuit
	LOW	HIGH		
compared signal /BIN1 - /BIN9 /AUX /OUT /PHI /PLO	≤0.5V	+5V--+24V	6mA	Internal pull-up voltage: LM1050 GND EXTV1: COM1
control signal /INDEX /EOM /ALARM	≤0.5V	+5V--+24V	5mA	Internal pull-up voltage : LM1050 GND EXTV2: COM2

7.2.3 7.2.3 HANDLER Interface board circuit

The output circuit for the comparison result is shown in the figure 7-6 below.

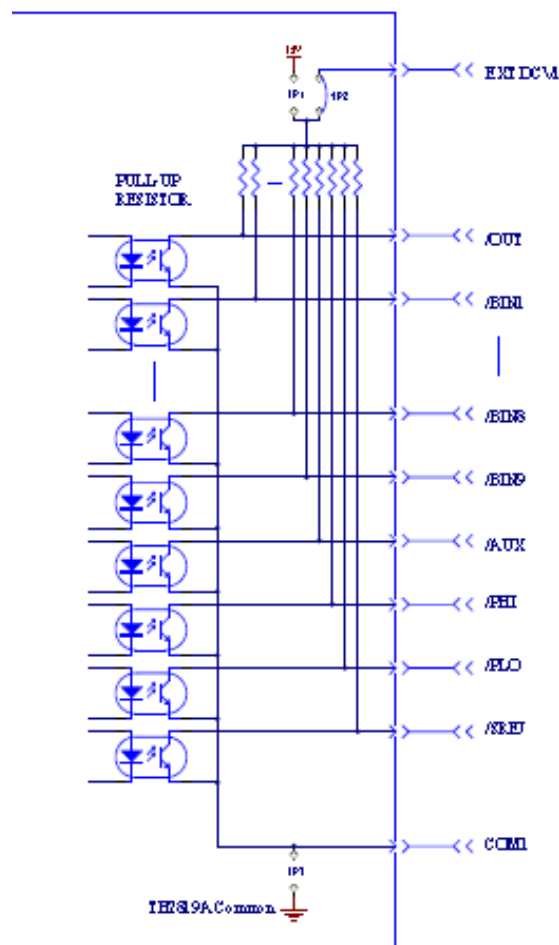

Figure 7-6 the output circuit for the comparison result

The output circuit for control signal is shown in the figure 7-7 below.

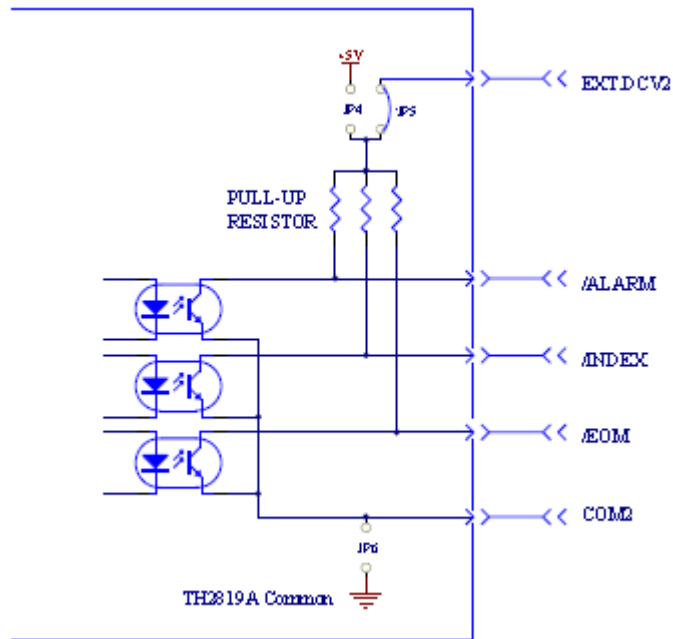

Figure 7-7 the output circuit for control signal

The input circuit for control signal is shown in the figure 7-8 below

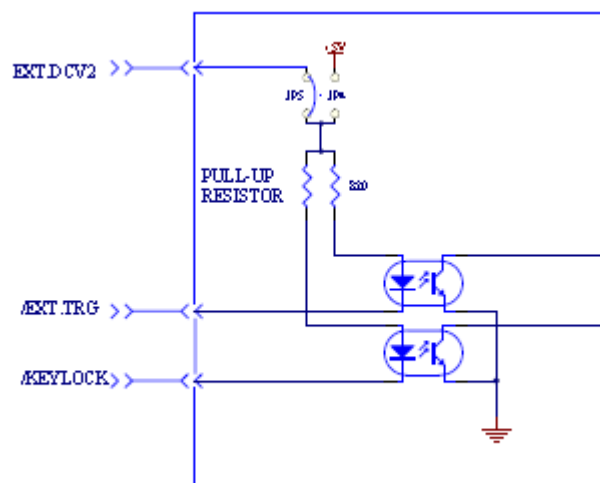

Figure 7-8 the input circuit for control signal

7.2.4 7.2.4 Operation

Before you use the HANDLER function, you should ensure that your instrument has install the HANDLER interface board. The following procedure will show you how to use the interface comparison and the list sweep comparison. The procedure for comparison setting :

- (1) Press the softkey [LIMIT TABLE]. LIMIT TABLE SETUP page will be displayed.
- (2) Set the standard value and the high limit and the low limit in LIMIT TABLE SETUP. Refer to the LCR menu key description to see more details.
- (3) Move the cursor to COMP field. The softkey area will display :
 - ON
 - OFF
- (4) Press the softkey ON to enable the comparison function.
- (5) Press [LCRZ], and then press the softkey BIN NO. or BIN COUNT, the DUT will be tested; at the same time, you can set the counter for the DUT and the auxiliary.

Note: COMP ON/OFF can be set in BIN COUNT page.

The procedure for list sweep comparison:

- (1) Press LIST SETUP, LIST SWEEP SETUP page will be displayed.
- (2) Set the sweep mode, sweep frequency point, reference value, the high limit and the low limit. Refer to the LCR menu key description to see more details.
- (3) Press [LCRZ].and then press the softkey LIST SWEEP, LIST SWEEP DISP page will be displayed. Refer to the LCR menu key description to see more details.

Note: the following methods can be used to improve the speed:

- (1) Set the range to the maximum that the capacitance may be, and lock this range.
- (2) Set Vm: OFF and Im: OFF in the MEAS SETUP page.
- (3) Test the DUT in the BIN COUNT page.