

AT SERIES TESTERS

AVAILABLE TESTS

| TEST | DESCRIPTION | TRANSFORMER APPLICATION | REASON FOR TEST |
|------------------|---|---|---|
| CTY | Continuity | All | Properly installed fixture and part. |
| R | DC Resistance | All | Correct wire used, integrity of terminations |
| LS | Inductance (Series circuit) | Most, but not usually line frequency | Checks primary turns, right grade of correctly assembled core material |
| LP | Inductance (Parallel circuit) | | |
| LSB | Inductance with Bias Current (Series Circuit) | Transformers that carry a dc bias current in normal operation | Check number of turns, right grade of correctly assembled core material |
| LPB | Inductance with Bias Current (Parallel Circuit) | | |
| LL | Leakage Inductance | SMPS, electronic ballasts | Check windings have been installed in the correct position relative to the core |
| LLO | | | |
| L2 | Inductance Match | SMPS, audio & telecom | Checks matching between windings |
| RLS | Equivalent Series Resistance | Most, but not usually line frequency | Check right grade of correctly assembled core material, and for shorted turns |
| RLP | Equivalent Parallel Resistance | | |
| QL | Quality Factor | | |
| D | Dissipation Factor (tanδ) | Capacitors | Check dielectric quality and assembly |
| C | Interwinding Capacitance | High frequency, isolating | Check winding positioning and insulation thickness between windings |
| C2 | Capacitance Match | SMPS, audio & telecom | Checks correct winding position on bobbin |
| TR | Turns Ratio and Phasing | Most, but usually not line frequency. | Check windings have correct turns and polarity |
| TRL | Turns Ratio by Inductance | | Check windings have correct turns |
| AT36 MAGI | Magnetising Current | Usually line frequency | Check primary turns and correct core material properly assembled |
| AT36 VOC | Open Circuit Voltage | | Check secondary turns and phasing |
| LVOC | Low Voltage Open Circuit | | |
| IR | Insulation Resistance | All | Check winding isolation check where safety is not involved |
| AT36 HPDC | Hi-Pot (DC) | All and especially those used for safety insulation | Check high voltage safety insulation |
| AT36 HPAC | Hi-Pot (AC) | | |
| AT36 SURG | Surge Stress Test | All, especially those with fine wire | Check interturn insulation, identify shorted turns. |
| AT36 WATT | Wattage | Line frequency | Right grade of correctly assembled core material. |
| AT36 STRW | Stress Wattage | Line frequency & high Frequency | Checks integrity of interturn insulation, the magnetic material and joints. |
| AT36 ILK | Leakage Current | All isolating, especially medical | Check for leakage of line current to ground |
| GBAL | General Longitudinal Balance | Audio & telecom | Checks common mode rejection ratio |
| LBAL | Longitudinal Balance | | Checks power lost within the transformer |
| ILOS | Insertion Loss | | Check power lost Vs frequency |
| RESP | Frequency Response | | Checks power lost within the transformer |
| RLOS | Return Loss | | Checks impedance at a given frequency |
| Z | Impedance | | Checks phase angle of complex impedance |
| ZB | Impedance with Bias Current | | Checks phase of voltage between windings |
| ANGL | Impedance Phase Angle | | Measuring & signal |
| PHAS | Interwinding Phase Angle | Transformers with variable / trimmable components | To adjust transformer parameter to desired value during test. |
| TRIM | Trimming Adjustment | | Perform external switching as part of the test program. |
| OUT | Output To User Port | | |

AT36 = Option available for the AT3600 only.

USA Tel: 919 431 0015 Fax: 919 431 0090 Email: sales@voltech.com

Europe Tel: +44 (0)1235 834555 Fax: +44 (0)1235 835016 Email: sales@voltech.co.uk

AT FIXTURES 1

FIXTURE SYSTEM INTRODUCTION

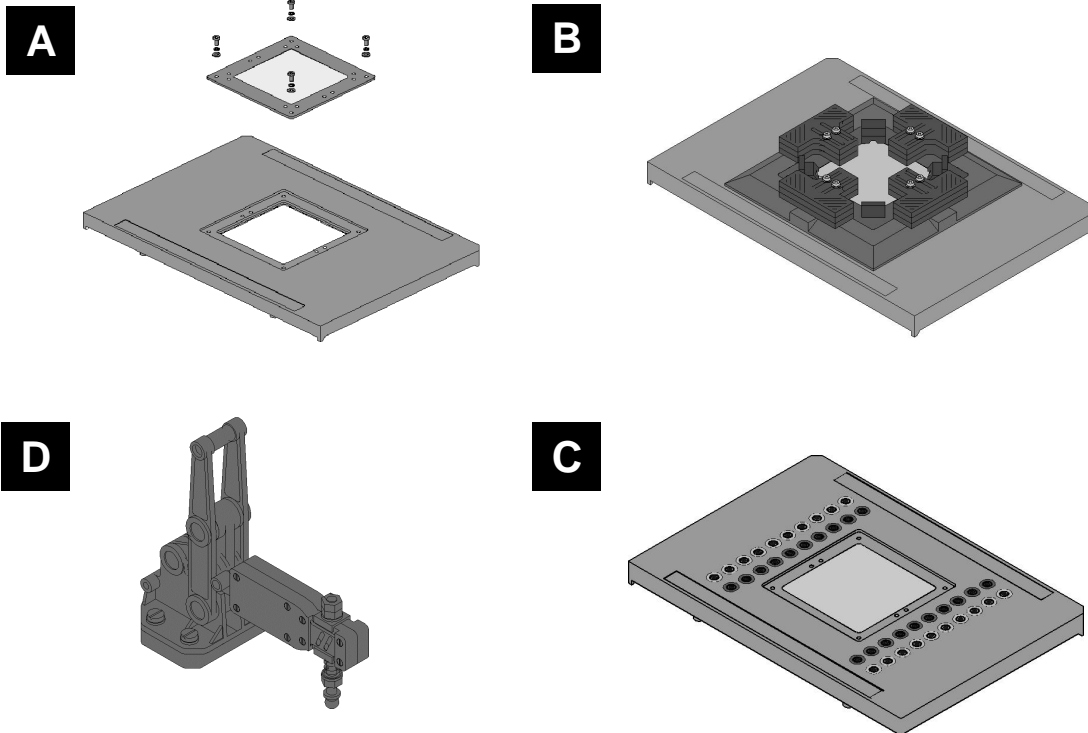

A. FIXTURE PLATE

Designed for mounting existing fixtures (such as Automech blocks) to an AT series tester. Comprises:

- Base plate (including contacts) with cover.
- Test piece interface plate.

B. CUSTOM FIXTURE KIT

A kit of parts for constructing your own fixtures. Interconnecting wire, test probes or clips and a drilling template will also be required. The custom fixture kit comprises:

- Base plate (contacts) with cover.
- Test piece interface plate.
- Probe housing box.
- Bezel.
- Guides (12 off)

C. 40 SOCKET FIXTURE

A fixture board fitted with 40 4mm sockets. 20 red (power) and 20 black (sense). The sockets are wired to the 40 contacts which align with the tester's 40 nodes. This complete fixture may be used for convenient wiring to existing fixtures or as a means of connecting flying leads and clips for use in developing test programs or testing small quantities.

D. FIXTURE CLAMP

The hand clamp is supplied with 7 height blocks and fixings.

TO ORDER

Specify the item and description on your order form:

- A 91-184 Fixture Plate
- B 91-185 Custom Fixture Kit
- C 91-186 40 Socket Fixture
- D 91-187 Fixture Clamp Kit

USA Tel: 919 431 0015 Fax: 919 431 0090 Email: sales@voltech.com

Europe Tel: +44 (0)1235 834555 Fax: +44 (0)1235 835016 Email: sales@voltech.co.uk

86-226 Iss4 © 2001 Voltech

<http://www.voltech.com>

Page 2 of 37

AT FIXTURES 2

THE FIXTURE PLATE

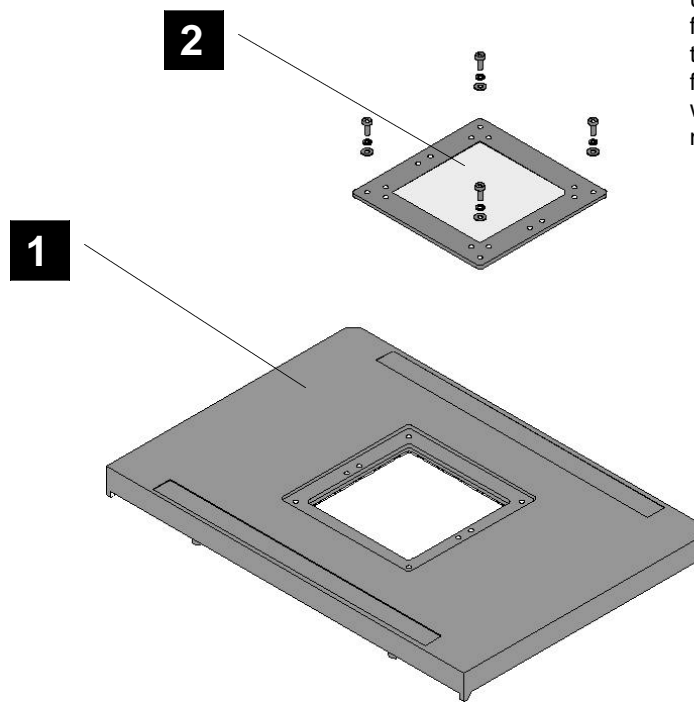

The Fixture Plate may be used to mount existing test fixtures onto an AT Series tester, or to create test fixtures for flying lead parts where spring probes are not required.

FIXTURE PLATE COMPONENTS

1. BASE PLATE.

Already fitted with 20 pairs of contacts, the base plate fits into the top of the tester and makes electrical connection to the tester's 20 pairs of test nodes.

The base plate has molded indents and guides to ease the fitting and wiring of larger test sockets and posts for flying leads.

2. COVER PLATE

This mounting plate allows convenient attachment of various sockets and connectors.

Please note that this plate is only 1mm in thickness and is therefore not suited for probe or Kelvin pin mounting. Refer to the Custom Fixture Kit for this purpose.

TO ORDER

To order the Fixture Plate specify 91-184 on your order form.

USA Tel: 919 431 0015 Fax: 919 431 0090 Email: sales@voltech.com

Europe Tel: +44 (0)1235 834555 Fax: +44 (0)1235 835016 Email: sales@voltech.co.uk

86-226 Iss4 © 2001 Voltech

<http://www.voltech.com>

Page 3 of 37

AT FIXTURES 3

THE CUSTOM FIXTURE KIT

The Custom Fixture Kit enables many types of transformers and other wound components to be quickly and securely connected to an AT Series tester for fast and accurate testing.

The system can accommodate transformer sizes of up to 63.5mm (2.5") and with suitable probes, parts with

surface mounting, pin, blade or flying lead connections can be connected.

The fixture system is supplied as detailed in the comprehensive user guide to fixture construction. The kit is designed such that fixtures can be quickly assembled using a basic vertical drill and simple hand tools.

FIXTURE KIT COMPONENTS

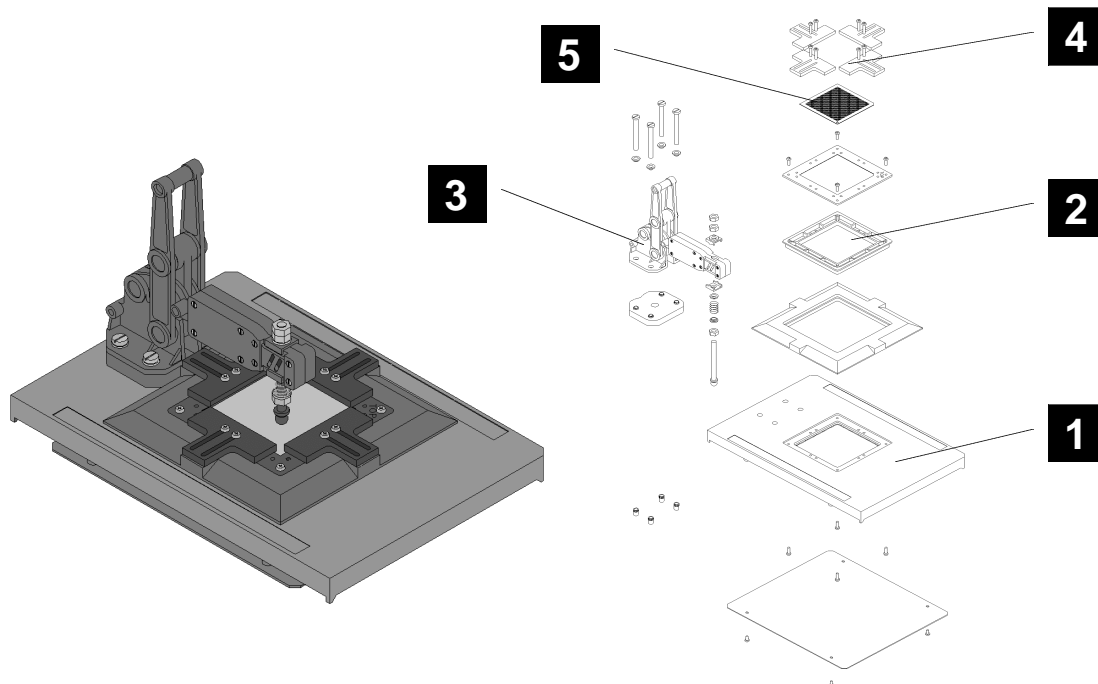

1. BASE PLATE.

Already fitted with 20 pairs of contacts, the base plate fits into the top of the tester and makes electrical connection to the tester's 20 pairs of test nodes.

The base plate has molded indents and guides to ease the fitting and wiring of larger test sockets and posts for flying leads.

2. PROBE HOUSING BOX

This 9mm thick plate is designed especially to hold a wide range of ATE probes and kelvin pins. See 'AT Fixtures 3'

3. CLAMP.

An optional hand clamp holds the test piece against the test probes. The clamp is adjustable in height and in spring pressure.

4. GUIDES.

12 adjustable guides are supplied to locate the test piece in the fixture quickly and accurately.

5. DRILLING TOOLS.

5 different pitches of template are available for marking and drilling the holes for test probes or kelvin pins.

TO ORDER

Custom Fixture Kit, order: 91-185
Fixture Clamp Kit, order: 91-187
Drilling Templates, Pack of Five, order: 50-307

Drilling Templates, Individual, order: 50-308 (1.27mm)
50-309 (2.00mm), 50-310 (2.50mm)
50-311 (2.54mm), 50-312 (3.81mm)

USA Tel: 919 431 0015 Fax: 919 431 0090 Email: sales@voltech.com

Europe Tel: +44 (0)1235 834555 Fax: +44 (0)1235 835016 Email: sales@voltech.co.uk

AT FIXTURES 4

THE 40 SOCKET FIXTURE

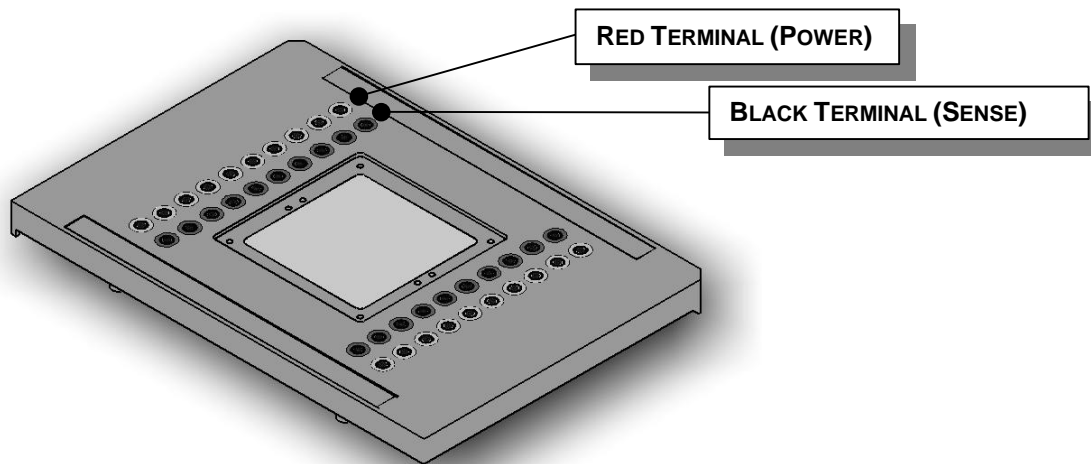

WHERE USED

Ideal for developing test programs or testing small batches of different wound components. The 40 socket fixture consists of 20 pairs of red and black 4mm shrouded safety sockets mounted and wired into a blank fixture.

A variety of clips and posts can be used to enable connection to the component under test. (See below). When testing larger quantities of the same component (50 or more) then a custom fixture solution is strongly recommended. Ask your Voltech supplier for details of the custom fixture kit.

CONNECTION LEAD SET

A selection of Kelvin and non-Kelvin crocodile clips and spring-loaded posts is available from Voltech, called the 'Connection Lead Set'. Each of the 'clips' is finished with 200mm red and black leads terminated in 4mm plugs.

The connection lead set consists of:
10 x Spring loaded connection posts.
10 x Kelvin Crocodile Clips.
10 x Non-Kelvin Crocodile Clips.
10 x Fine Non Kelvin Clips.

TO ORDER

To order the 40 Socket Fixture specify 91-186 on your order form.
To order the Connection Lead Set specify 78-030 on your order form.

USA Tel: 919 431 0015 Fax: 919 431 0090 Email: sales@voltech.com

Europe Tel: +44 (0)1235 834555 Fax: +44 (0)1235 835016 Email: sales@voltech.co.uk

86-226 Iss4 © 2001 Voltech

<http://www.voltech.com>

Page 5 of 37

AT FIXTURES 5

FIXTURE SYSTEM PROBES AND CLIPS

With the Voltech fixture system, durable quality fixtures may be constructed accurately and swiftly with the aid of a small vertical pillar drill and simple hand tools. The probes and clips described here are intended as a guide to what is available; other types from other manufacturers may be suitable.

To purchase the probes and clips, please contact the manufacturers listed.

Complete fixture manufacturing details are contained in the construction handbook that is supplied with each fixture.

KELVIN BLADES

Ideally suited to precision measurements on PCB mounting transformers with pins or blades up to 1.5mm dia. The Kelvin blades provide a four terminal (power and sense connection) directly to the transformer pin. Kelvin blades can be quickly fitted into the probe housing box and mixed with spring probes (as below) to make core connections.

Contact Voltech or:
Wilco Fixtures and Pins
17th Smith Street
Fitchburg, MA 01420
USA
Tel: +1 978 345 1929

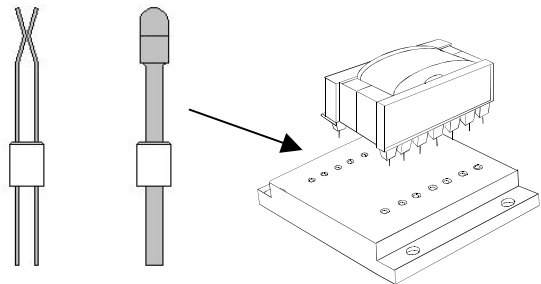

SPRING PROBES

Available in a wide variety of styles and sizes, spring probes are fitted into the probe housing box and are suitable for transformers with surface mounting, pin and blade connections as well as for making contact with the transformer core. A fixture clamp is required to hold the transformer against the spring pressure of the probes.

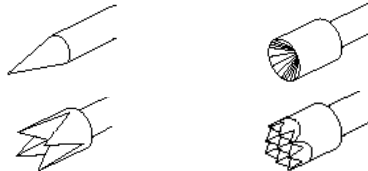

USA
Everett Charles Technologies
TEL: 909 625 5551 <http://www.ectinfo.com>

IDI
913 342 5544

QA Technologies
603 926 0348

UK
Coda Systems Ltd.
+44 (0) 1376 343802 <http://www.coda-systems.co.uk/>

Teknis Ltd
+44 (0) 1823 481248

Probus Electronics Ltd
+44 (0) 181 866 7272

TERMINALS FOR FLYING LEADS

Flying leads and tags can all be accommodated by the fixture system.

Molded indents in the base plate aid the drilling and fitting of 4mm sockets (universally available).

Kelvin axial and radial sockets are available from Loranger at www.loranger.com

Kelvin alligator clips are available from:
USA Globtek 201 784 1000
UK Bulgin +44 (0) 181 594 5588

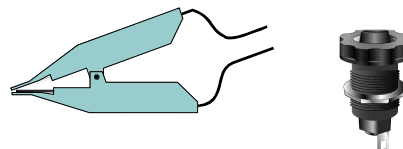

AT TEST OPTIONS

CTY, R - CONTINUITY AND RESISTANCE TEST OPTIONS

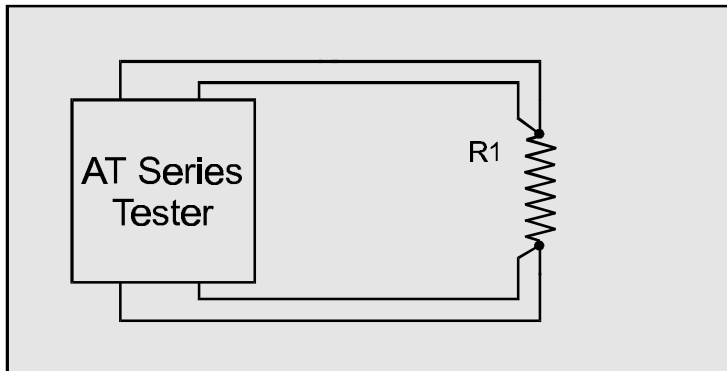

R1 represents the resistance of the copper wire used to wind the transformer. When current flows in the winding, the resistance causes losses in the winding (I^2R losses), which cause undesirable heating within the transformer.

In addition, the winding resistance causes a voltage drop in the winding when current flows, causing the output voltage to fall with increasing load.

WHERE USED

The continuity test should be used as the first test in the program to check that the transformer has been inserted correctly into the test fixture. The continuity test is faster than the DC resistance test, but the same limit is applied to every winding, and therefore CTY is suitable for finding only major winding defects.

The DC resistance test also checks for connection between the transformer and the test fixture, but it does this on a winding by winding basis. It is used to check each winding for manufacturing faults such as incorrect wire gauge or poor termination.

MEASUREMENT CONDITIONS

For either test, the winding resistance is calculated by measuring the voltage across and the current through a winding. For a specified resistance of greater than $10k\Omega$, the test signal is a fixed 8.0V dc voltage. Up to and including $10k\Omega$, a programmable current source is used.

For continuity, one test limit is set for all the windings on the transformer, so the test limit must be chosen to be higher than the resistance of the biggest winding. $10k\Omega$ is the value that should be used for optimum speed of the continuity test.

TEST SPECIFICATION

| Test | Measurement Range | Basic Accuracy |
|------|------------------------------|----------------|
| CTY | $10k\Omega$ to $10M\Omega$ | n/a |
| R | $10\mu\Omega$ to $10M\Omega$ | 0.1% |

TO ORDER

To order continuity, ask for CTY and for DC Resistance ask for R on your order form.

USA Tel: 919 431 0015 Fax: 919 431 0090 Email: sales@voltech.com

Europe Tel: +44 (0)1235 834555 Fax: +44 (0)1235 835016 Email: sales@voltech.co.uk

86-226 Iss4 © 2001 Voltech

<http://www.voltech.com>

Page 7 of 37

AT TEST OPTIONS

LS, LP - SERIES AND PARALLEL INDUCTANCE TEST OPTIONS

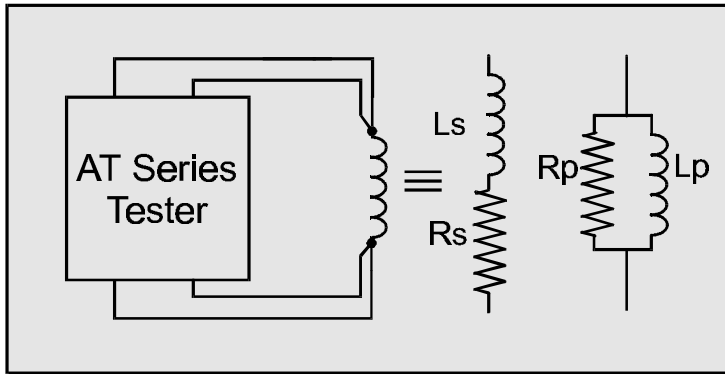

Inductance is the electrical parameter that is commonly used to check that a high frequency transformer has been constructed according to its design and that it will operate properly in use.

The inductance of a winding is determined by the number of turns and the construction and dimensions of the core materials; it may also vary with test conditions such as voltage and frequency.

WHERE USED

The series and parallel inductance tests are used when testing signal, pulse, switched mode and similar transformers with ferrite type cores, where the inductance remains the same from small signals up to the operating conditions.

Faults in numbers of turns, core material and core gapping may be determined using this test.

For line frequency iron cored transformers where the inductance varies rapidly with voltage a magnetizing current test (MAGI) is recommended.

MEASUREMENT CONDITIONS

To measure inductance, the tester applies an ac voltage across the selected windings, and measures the voltage across, and the current through, the winding.

Using harmonic analysis, the measured voltage is divided by the current to obtain the complex impedance from which the inductance is extracted.

Generally, it is not necessary to measure the inductance at the normal operating conditions of the transformer, which could involve, for example, hundreds of volts. This is because the core material can normally be assumed to behave linearly in the operating region, and the inductance measured at a low level represents the inductance that will appear in use.

TEST SPECIFICATION

| Test | Measurement Range | Test Voltage | Test Frequency | Basic Accuracy |
|-----------|-------------------|--------------|----------------|----------------|
| LS and LP | 1nH to 1MH | 1mV to 5V | 20Hz to 3MHz | 0.05% |

TO ORDER

To order, ask for LS for series inductance and/or LP for parallel inductance on your order form.

USA Tel: 919 431 0015 Fax: 919 431 0090 Email: sales@voltech.com

Europe Tel: +44 (0)1235 834555 Fax: +44 (0)1235 835016 Email: sales@voltech.co.uk

86-226 Iss4 © 2001 Voltech

<http://www.voltech.com>

Page 8 of 37

AT TEST OPTIONS

LSB, LPB - SERIES AND PARALLEL INDUCTANCE WITH BIAS TEST OPTIONS

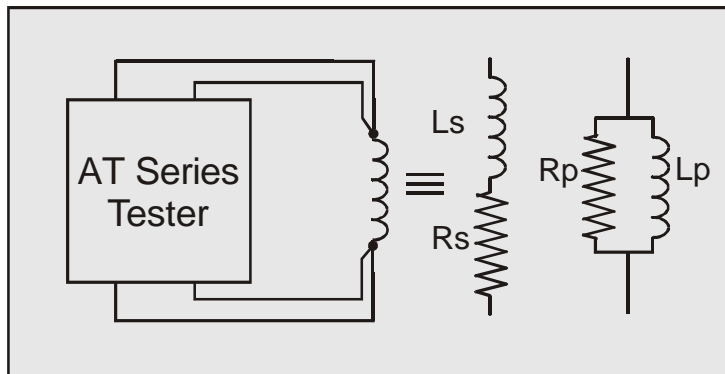

Inductance is the electrical parameter that is commonly used to check that a high frequency transformer has been constructed according to its design and that it will operate properly in use. As well as operating with ac signals, some transformers and chokes are designed to operate with a dc bias current flowing in a winding.

The inductance of a winding is determined by the number of turns and the construction and dimension of the core materials; it may also vary with test conditions such as voltage and frequency.

WHERE USED

The series and parallel inductance tests are used with dc bias when testing transformers with ferrite type cores that carry a significant dc bias current in normal operation. Such transformers and chokes are common in switched mode power conversion circuits.

Faults in numbers of turns, core material and core gapping may be determined using this test.

For line frequency iron cored transformers where the inductance varies rapidly with voltage a magnetizing current test (MAGI) is recommended. See also the LS and LP tests for testing transformers where a dc bias current is not required.

MEASUREMENT CONDITIONS

To measure inductance with dc bias, the tester first applies and stabilizes the dc bias current and then applies an ac voltage across the selected winding. The tester measures the voltage across, and the current through, the winding.

Using harmonic analysis, the measured voltage is divided by the current to obtain the complex impedance from which the inductance is extracted.

Generally, it is not necessary to measure the inductance at the normal operating conditions of the transformer, which could involve, for example, hundreds of volts or several amps of bias. This is because the core material can normally be assumed to behave linearly in the operating region, and the inductance measured at a low level represents the inductance that will appear in use.

TEST SPECIFICATION

| Test | DC Bias | Measure Range | Test Voltage | Test Frequency | Basic Accuracy |
|-------------|----------------------------------|---------------|--------------|----------------|----------------|
| LSB and LPB | 1mA to 400mA (1mA to 1A, ATi) | 1nH to 1MH | 1mV to 5V | 20Hz to 3MHz | 0.05% |

TO ORDER

To order the series inductance with dc current bias test, ask for LSB on your order form.
To order the parallel inductance with dc current bias test, ask for LPB on your order form.

USA Tel: 919 431 0015 Fax: 919 431 0090 Email: sales@voltech.com

Europe Tel: +44 (0)1235 834555 Fax: +44 (0)1235 835016 Email: sales@voltech.co.uk

86-226 Iss4 © 2001 Voltech

http://www.voltech.com

Page 9 of 37

AT TEST OPTIONS

LL, LLO – LEAKAGE INDUCTANCE, LEAKAGE INDUCTANCE WITH OFFSET TEST OPTIONS

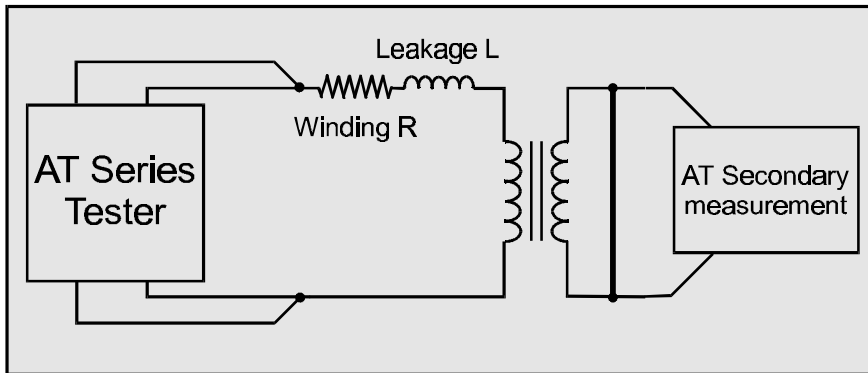

Due to imperfections in the coupling between windings, a short-circuited transformer acts as if there is inductive impedance in series with the winding.

This impedance is known as the leakage inductance. Low leakage inductance implies good coupling; high leakage inductance, poor coupling.

WHERE USED

Leakage inductance is important in many transformer designs such as switching power supply power transformers and electronic lighting ballasts.

The test is used to ensure that the windings and core have been positioned correctly.

MEASUREMENT CONDITIONS

Leakage inductance is tested by measuring the inductance of a primary winding when one or more secondary windings are shorted out. (See also the LS test). Typically, the impedance to be measured is very small, so a constant current ac test signal is used to provide stable, accurate results over a broad range of values.

The short circuit can be applied automatically by the tester without using any external switches or components.

The tester compensates for the impedance of wiring and other connections in the shorted path during a leakage inductance test, but when measuring a leakage inductance below 1 μ H it may not be possible to properly compensate for all parasitic effects. In this case an offset inductance may be specified during programming. (LLO test option only).

TEST SPECIFICATION

| Test | Measurement Range | Test Current | Test Frequency | Basic Accuracy |
|---------|--|---------------------|----------------|----------------|
| LL, LLO | 1nH to 1kH | 20 μ A to 100mA | 20Hz to 3MHz | 0.1% |
| LLO | Offset Range: -1H to +1H in 1nH steps | | | |

TO ORDER

To order the leakage inductance test, ask for LL on your order form.

To order the leakage inductance test with user offset, ask for LLO on your order form.

USA Tel: 919 431 0015 Fax: 919 431 0090 Email: sales@voltech.com

Europe Tel: +44 (0)1235 834555 Fax: +44 (0)1235 835016 Email: sales@voltech.co.uk

86-226 Iss4 © 2001 Voltech

<http://www.voltech.com>

Page 10 of 37

AT TEST OPTIONS

L2 – INDUCTANCE MATCH TEST OPTION

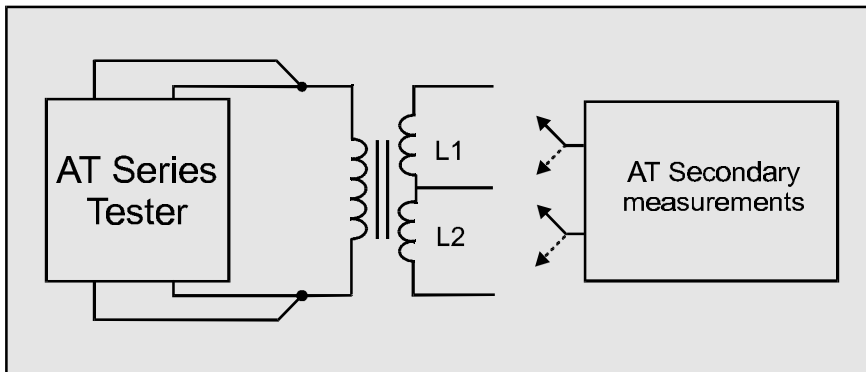

The inductance of a winding is determined by the number of turns and the construction and dimension of the core materials; it may also vary with test conditions such as voltage and frequency. See the LS and LP tests.

Windings consisting of the same number of turns and wound on the same core should have the same inductance value.

WHERE USED

The inductance match test – as opposed to an ordinary inductance measurement (LS or LP) - is used on power conversion, audio and telecommunications transformers where it is important that the inductance of different pairs

of windings is controlled and matched to a specified ratio. The absolute value of the inductances may be of less importance to the performance of the transformer than the match between two inductances.

MEASUREMENT CONDITIONS

To measure inductance match, the tester makes two series inductance measurements (see the LS test) and compares the two results. Limits for the match of the two measured inductances may be set in terms of the ratio between them (e.g. 1:1 \pm 5%).

By adding further inductance match tests to the program any number of inductances can be tested for match.

TEST SPECIFICATION

| Test | Measurement Range | Test Voltage | Test Frequency | Basic Accuracy |
|------|--------------------|--------------|----------------|----------------|
| L2 | 1:10000 to 10000:1 | 1mV to 5V | 20Hz to 3MHz | 0.1% |

TO ORDER

To order the Inductance Match test, ask for L2 on your order form.

USA Tel: 919 431 0015 Fax: 919 431 0090 Email: sales@voltech.com

Europe Tel: +44 (0)1235 834555 Fax: +44 (0)1235 835016 Email: sales@voltech.co.uk

86-226 Iss4 © 2001 Voltech

<http://www.voltech.com>

Page 11 of 37

AT TEST OPTIONS

RLS, RLP - EQUIVALENT SERIES AND PARALLEL RESISTANCE TEST OPTIONS

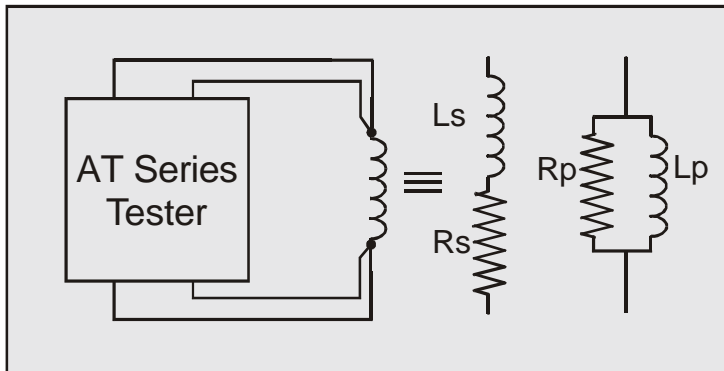

The equivalent ac resistance of a winding may be different to that measured at dc. The resistive part of the complex winding impedance will vary with frequency due to skin and proximity effects.

The transformer I^2R losses will then be different to those calculated using the DC resistance.

WHERE USED

The equivalent series or parallel resistance test is used to determine the ac equivalent resistances of a transformer. As opposed to the dc resistance test, R , which uses dc voltages, the RLS and RLP tests apply ac voltages at a specified voltage and frequency.

The measurement of ac resistance at a particular frequency helps to ensure that the winding has been correctly wound and with the correct gauge of wire.

MEASUREMENT CONDITIONS

To measure equivalent resistances, the AT3600 applies an ac voltage across the selected winding, and measures the voltage across and the current through the winding. Using harmonic analysis, the measured voltage is divided

by the current to obtain a complex impedance from which the equivalent series and parallel resistances are obtained.

TEST SPECIFICATION

| Test | Measurement Range | Test Voltage | Test Frequency | Basic Accuracy |
|----------|--------------------------------|--------------|----------------|----------------|
| RLS, RLP | 10 $\mu\Omega$ to 10M Ω | 1mV to 5V | 20Hz to 3MHz | 0.05% |

TO ORDER

To order the Equivalent Series Resistance test, ask for RLS on your order form.
To order the Equivalent Parallel Resistance test, ask for RLP on your order form.

USA Tel: 919 431 0015 Fax: 919 431 0090 Email: sales@voltech.com

Europe Tel: +44 (0)1235 834555 Fax: +44 (0)1235 835016 Email: sales@voltech.co.uk

86-226 Iss4 © 2001 Voltech

<http://www.voltech.com>

Page 12 of 37

AT TEST OPTIONS

QL - QUALITY FACTOR TEST OPTION

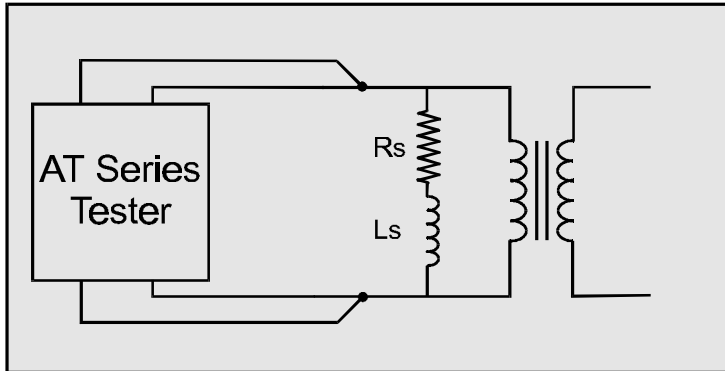

When a transformer is energized, the changing magnetic field in the core causes two types of losses:- hysteresis losses and eddy current losses. The total of these losses can be represented on the equivalent circuit of a transformer by a resistance associated with the inductance of the winding.

For this equivalent circuit the Quality Factor Q is defined as:

$$Q = \frac{\omega L_s}{R_s} \text{ where } \omega = 2\pi f$$

For a given inductance, the lower the equivalent series resistance, the higher is the value of Q, i.e. the 'better' the coil.

WHERE USED

The Q factor test would normally be used for signal, pulse and switched mode power transformers, where the normal operating conditions require only small excursions of the B-H curve, never extending beyond the linear region.

A Q Factor test will help to determine that the correct wires and cores have been correctly assembled for the part under test.

MEASUREMENT CONDITIONS

To measure Quality Factor, the tester applies an ac voltage across the selected winding, and measures the voltage across and the current through the winding. Using

harmonic analysis, the measured voltage is divided by the current to obtain a complex impedance from which the Quality Factor is obtained.

TEST SPECIFICATION

| Test | Measurement Range | Test Voltage | Test Frequency | Basic Accuracy |
|------|-------------------|--------------|----------------|----------------|
| QL | 0.001 to 1000 | 1mV to 5V | 20Hz to 3MHz | 0.5% |

TO ORDER

To order the Quality factor test, ask for QL on your order form.

USA Tel: 919 431 0015 Fax: 919 431 0090 Email: sales@voltech.com

Europe Tel: +44 (0)1235 834555 Fax: +44 (0)1235 835016 Email: sales@voltech.co.uk

AT TEST OPTIONS

D – DISSIPATION FACTOR TEST OPTION

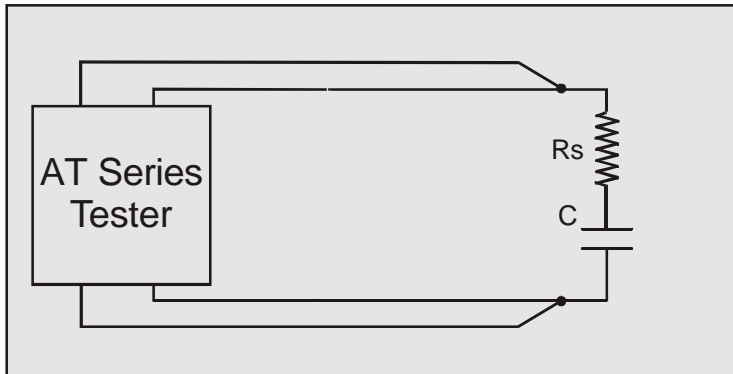

'Dissipation factor' or 'tanδ' is most often used as a measurement of the losses in a capacitor. It is analogous to 'Q' for an inductor.

For this equivalent circuit the Quality Factor Q is defined as:

$$D = \frac{R_s}{1 / \omega C_s} \quad (\text{where } \omega = 2\pi f)$$

For a given capacitance, the lower the equivalent series resistance, the lower is the value of D, i.e. the 'better' the capacitor.

WHERE USED

The Dissipation factor test, D, would normally be used on capacitors of all types.

A dissipation factor test will help to determine that the correct dielectric material has been used and that the capacitor has been correctly assembled.

Please note that although it is possible to program this test from the PC Editor, it is not possible to place a capacitor on the schematic.

MEASUREMENT CONDITIONS

To measure the Dissipation Factor, the tester applies an ac voltage across the capacitance, and measures the voltage across and the current through the capacitance.

Using harmonic analysis, the measured voltage is divided by the current to obtain a complex impedance from which the Dissipation Factor is obtained.

TEST SPECIFICATION

| Test | Measurement Range | Test Voltage | Test Frequency | Basic Accuracy |
|------|-------------------|--------------|----------------|----------------|
| D | 0.001 to 1000 | 1mV to 5V | 20Hz to 3MHz | 0.5% |

TO ORDER

To order the Dissipation factor test, ask for D on your order form.

USA Tel: 919 431 0015 Fax: 919 431 0090 Email: sales@voltech.com

Europe Tel: +44 (0)1235 834555 Fax: +44 (0)1235 835016 Email: sales@voltech.co.uk

AT TEST OPTIONS

C – INTERWINDING CAPACITANCE TEST OPTION

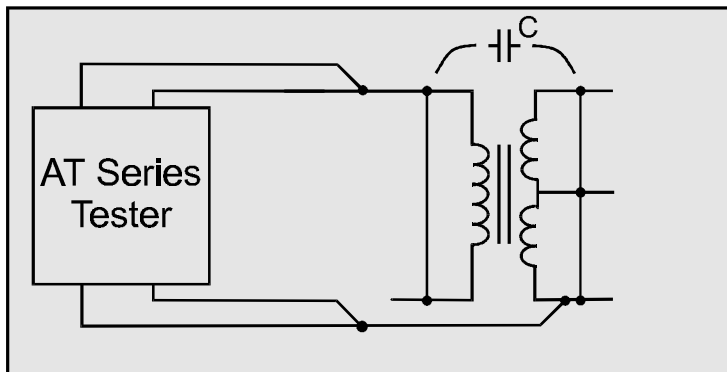

Capacitance occurs in transformers due to the physical proximity of, and electrostatic coupling between, different turns of wire.

In general, the capacitance is distributed between different layers within a winding, and between the outside layer of one winding and the inside layer of the next. Although the capacitance is distributed across windings, it is usually represented by a simple equivalent circuit showing a single capacitance from one winding to the next.

WHERE USED

An interwinding capacitance test can be used to check for correct winding position and to check for the correct insulation thickness between windings where isolation between primary and secondary windings is important.

The test can be used to check for capacitance between windings where, for example, too large a capacitance may couple unwanted noise signals between power and control circuits.

MEASUREMENT CONDITIONS

To measure capacitance, the tester applies an ac voltage between the windings to be tested, usually with all taps on each winding shorted together. It then measures the voltage between the windings, and the resulting current. Dividing the voltage by the current gives the interwinding

impedance, from which the capacitance is extracted using harmonic analyses.

Capacitance is measured as part of a complex impedance. The AT Series testers use a parallel equivalent circuit for capacitance measurements.

TEST SPECIFICATION

| Test | Measurement Range | Test Voltage | Test Frequency | Basic Accuracy |
|------|-------------------|--------------|----------------|----------------|
| C | 100fF to 1mF | 1mV to 5V | 20Hz to 3MHz | 0.1% |

TO ORDER

To order the Interwinding Capacitance test, ask for C on your order form.

USA Tel: 919 431 0015 Fax: 919 431 0090 Email: sales@voltech.com

Europe Tel: +44 (0)1235 834555 Fax: +44 (0)1235 835016 Email: sales@voltech.co.uk

AT TEST OPTIONS

C2 – INTERWINDING CAPACITANCE MATCH TEST OPTION

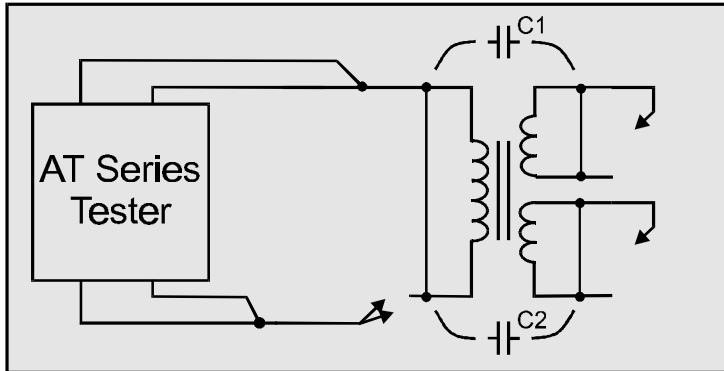

Capacitance occurs in transformers due to the physical proximity of, and electrostatic coupling between, different turns of wire.

In general, the capacitance is distributed between different layers within a winding, and between the outside layer of one winding and the inside layer of the next. Although the capacitance is distributed, it is usually represented by a simple equivalent circuit showing a single capacitance from one winding to the next.

WHERE USED

The capacitance match test – as opposed to an ordinary capacitance measurement (C) - is used on power conversion, audio and telecommunications transformers where it is important that the capacitance between different pairs of windings is controlled and matched.

Mismatched capacitances may couple unwanted noise signals from one winding to another or ground. The test will determine if one winding has been placed incorrectly or if the wrong thickness of insulation has been used.

MEASUREMENT CONDITIONS

To measure capacitance match, the tester makes two capacitance measurements (see the C test) and compares the two results. Limits for the match of the two measured capacitances may be set in terms of the ratio between them (e.g. 1:1 \pm 5%).

By adding further capacitance match tests to the program any number of interwinding capacitances can be tested for match. The AT Series testers use a parallel equivalent circuit for capacitance measurements.

TEST SPECIFICATION

| Test | Measurement Range | Test Voltage | Test Frequency | Basic Accuracy |
|------|-------------------|--------------|----------------|----------------|
| C2 | 1:1000 to 1000:1 | 1mV to 5V | 20Hz to 3MHz | 0.2% |

TO ORDER

To order the Interwinding Capacitance Match test, ask for C2 on your order form.

USA Tel: 919 431 0015 Fax: 919 431 0090 Email: sales@voltech.com

Europe Tel: +44 (0)1235 834555 Fax: +44 (0)1235 835016 Email: sales@voltech.co.uk

86-226 Iss4 © 2001 Voltech

<http://www.voltech.com>

Page 16 of 37

AT TEST OPTIONS

TR – TURNS RATIO AND PHASING TEST OPTION

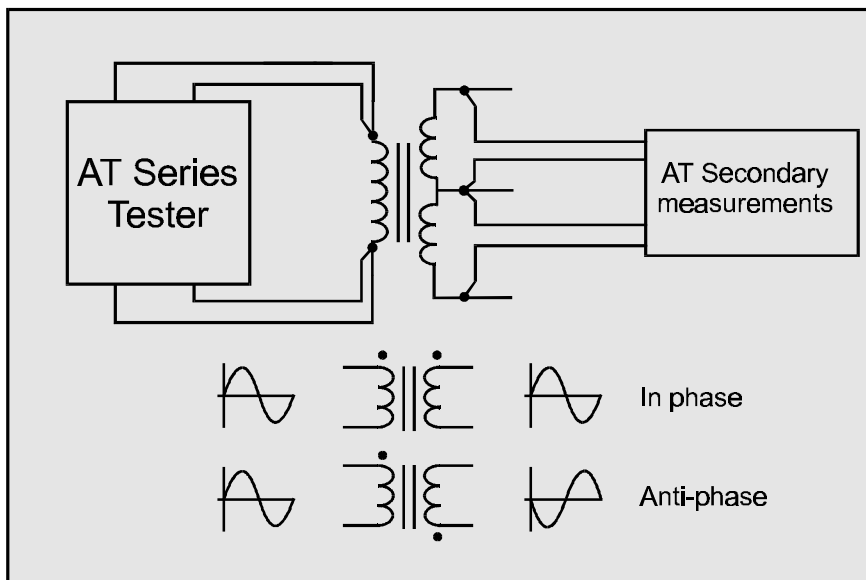

Applying an ac voltage to the primary of the transformer will produce an ac voltage in the secondary. Turns ratio describes the voltage ratio of the measured voltages from one winding and another.

The secondary voltage may be in phase with the primary voltage or it may be anti-phase depending on the winding and the termination of the windings.

WHERE USED

The turns ratio test is used to confirm that windings have the correct ratio of turns between them, and that the phasing of the windings is correct. This test is the preferred test for signal, pulse and switched mode power

transformers where the normal operating conditions require only small excursions of the B-H curve, never extending beyond the linear region.

MEASUREMENT CONDITIONS

To measure turns ratio, a test source is applied to one winding, the energized winding. The voltages across two other windings (one of which may be the energized winding) are measured. The turns ratio is then measured

by dividing one measured voltage by the other, and making a compensation for the effects of winding resistance.

TEST SPECIFICATION

| Test | Measurement Range | Test Voltage | Test Frequency | Basic Accuracy |
|------|---------------------|--------------|----------------|----------------|
| TR | 1:100,000 100,000:1 | 1mV to 5V | 20Hz to 3MHz | 0.1% |

TO ORDER

To order the Turns Ratio and Phasing test, ask for TR on your order form.

USA Tel: 919 431 0015 Fax: 919 431 0090 Email: sales@voltech.com

Europe Tel: +44 (0)1235 834555 Fax: +44 (0)1235 835016 Email: sales@voltech.co.uk

86-226 Iss4 © 2001 Voltech

<http://www.voltech.com>

Page 17 of 37

AT TEST OPTIONS

TRL – TURNS RATIO BY INDUCTANCE TEST OPTION

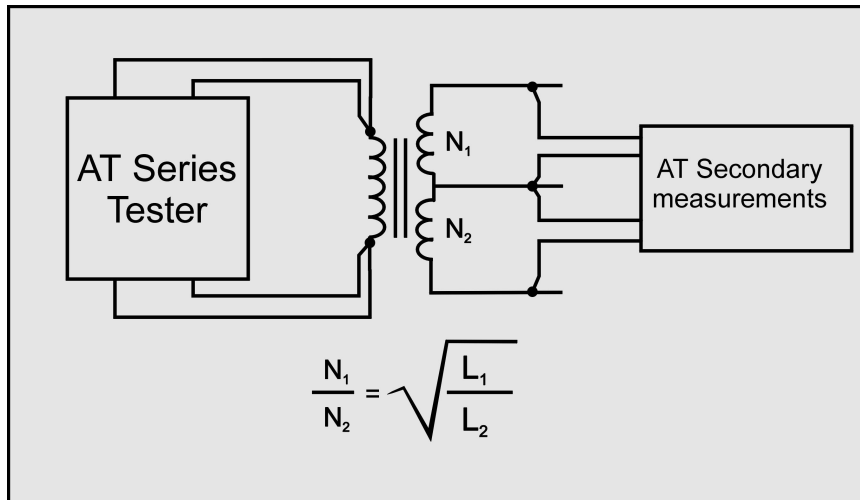

The correct ratio of the number of turns on one winding to the number of turns on another winding is important for the proper operation of any transformer.

The turns ratio is often determined by calculating the ratio of the voltages produced across the windings (the TR test), but it can also be determined from a measurement of the two winding inductances.

The inductance of a winding is proportional to the number of turns squared:

$$L \propto N^2$$

and the turns ratio can thus be calculated as the square root of the inductance ratio.

WHERE USED

The turns ratio by inductance test is used on transformers that have poor coupling between windings and where a turns ratio by voltage (TR) test may not produce the expected result.

For example, transformers for electronic lighting ballasts are often deliberately wound to have relatively large

values of leakage inductance. During voltage TR testing, some of the voltage will appear across the leakage inductance and alter the result.

The TRL test is not effected by leakage inductance and other parasitic components in this way.

MEASUREMENT CONDITIONS

To measure turns ratio by inductance, two inductance measurements are made - one on each winding. The same voltage (at the specified amplitude and frequency) is applied to each winding in turn and the inductance of each

is determined from the measured voltage and current using harmonic analysis. The turns ratio is then calculated as the square root of the ratio of the inductances.

TEST SPECIFICATION

| Test | Measurement Range | Test Voltage | Test Frequency | Basic Accuracy |
|------|-------------------|--------------|----------------|----------------|
| TRL | 1:100 100:1 | 1mV to 5V | 20Hz to 3MHz | 0.1% |

TO ORDER

To order the Turns Ratio by Inductance test, ask for TRL on your order form.

USA Tel: 919 431 0015 Fax: 919 431 0090 Email: sales@voltech.com

Europe Tel: +44 (0)1235 834555 Fax: +44 (0)1235 835016 Email: sales@voltech.co.uk

86-226 Iss4 © 2001 Voltech

<http://www.voltech.com>

Page 18 of 37

AT TEST OPTIONS

AT3600
ONLY

MAGI – MAGNETIZING CURRENT TEST OPTION

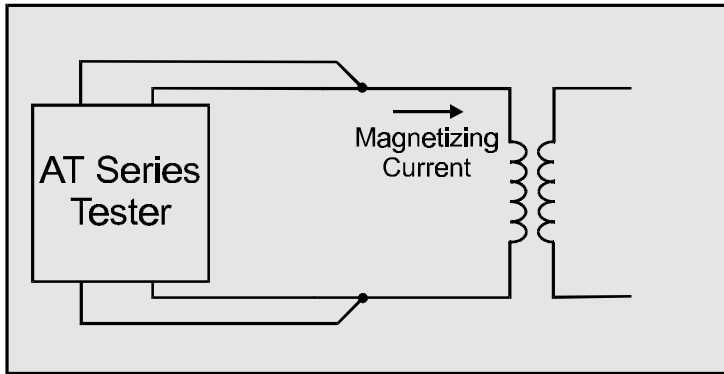

Magnetizing current is the term used to denote the total current that flows into the primary of a transformer when the transformer is energized at a specific voltage and frequency, with the secondaries open circuited.

Although known as the magnetizing current, it is actually the combination of the current required to magnetize the core and the current required to supply the losses in the core.

WHERE USED

The magnetizing current test is used to confirm that a transformer has been assembled properly, with the appropriate number of turns, the right grade of magnetic material for the core, and the correct air gap if required.

The magnetizing current test is the preferred test for line frequency transformers constructed using laminated iron cores which are designed to operate over the full extent of the B-H curve.

MEASUREMENT CONDITIONS

When making a magnetizing current measurement, the normal test signal applied to the primary winding is the full working voltage at the lowest working frequency.

quicker measurement. For repeatable results, the AT3600 does not start measurements until the transient has settled.

In practice, the magnetizing current waveform may well have a transient component following the switch-on of the test voltage. The AT3600 uses an energizing sequence that minimizes the transient and therefore allows for a

The AT3600 allows either the true rms current or the mean-sense current to be measured.

TEST SPECIFICATION

| Test | Measurement Range | Test Voltage | Test Frequency | Basic Accuracy |
|------|-----------------------|--------------|----------------|----------------|
| MAGI | 1 μ A to 2A(3Apk) | 1 to 270V | 20Hz to 1500Hz | 0.1% |

TO ORDER

To order the Magnetizing Current test, ask for MAGI on your order form.

This option is available for the AT3600 only.

USA Tel: 919 431 0015 Fax: 919 431 0090 Email: sales@voltech.com

Europe Tel: +44 (0)1235 834555 Fax: +44 (0)1235 835016 Email: sales@voltech.co.uk

86-226 Iss4 © 2001 Voltech

<http://www.voltech.com>

Page 19 of 37

AT TEST OPTIONS

AT3600
ONLY

VOC – VOLTAGE OPEN CIRCUIT TEST OPTION

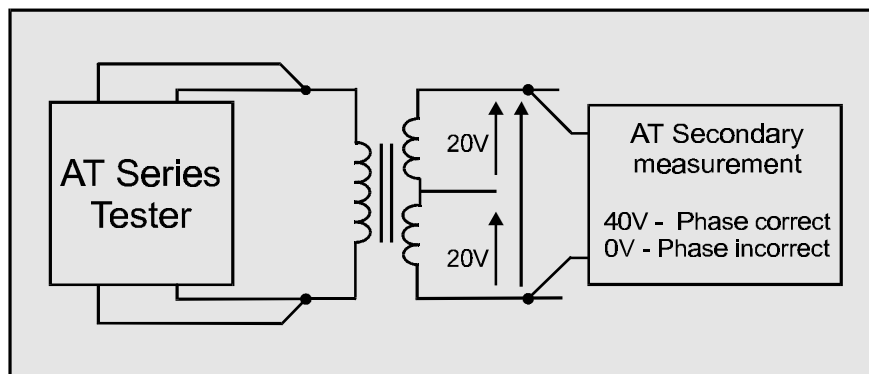

Open Circuit Voltage (VOC) is the voltage appearing across a secondary winding when the primary is energized at a specified voltage and frequency, with the secondary at no load.

The voltage is dependent not only on the turns ratio of the transformer, but also on the voltage drop in the primary winding due to magnetizing current.

WHERE USED

Open circuit voltage measurements are the preferred tests for line frequency transformers, designed to operate over the full extent of the B-H curve, including the non-linear

regions. An open circuit voltage test is used to confirm the turns ratio between winding and also the phasing of windings on these types of transformers.

MEASUREMENT CONDITIONS

Open circuit voltage is measured by applying an ac test voltage to a selected winding (usually a primary winding), and measuring the resulting voltage produced on another winding.

The AT3600 takes measurements using either a normal ac (rms) measurement or a dc (mean) measurement. Generally, the ac rms value would be used, but the dc

measurement could be used if, for example, the transformer under test is fitted with a rectifying diode.

When applying the test voltage, the AT3600 uses an energizing sequence that allows for the fastest measurement, while ensuring that the core does not go into saturation during any part of the test.

TEST SPECIFICATION

| Test | Measurement Range | Test Voltage | Test Frequency | Basic Accuracy |
|------|---------------------|--------------|----------------|----------------|
| VOC | 100 μ V to 500V | 1 to 270V | 20Hz to 1500Hz | 0.1% |

TO ORDER

To order the Voltage Open Circuit test, ask for VOC on your order form.

This option is available for the AT3600 only.

USA Tel: 919 431 0015 Fax: 919 431 0090 Email: sales@voltech.com

Europe Tel: +44 (0)1235 834555 Fax: +44 (0)1235 835016 Email: sales@voltech.co.uk

86-226 Iss4 © 2001 Voltech

<http://www.voltech.com>

Page 20 of 37

AT TEST OPTIONS

LVOC – LOW VOLTAGE OPEN CIRCUIT TEST OPTION

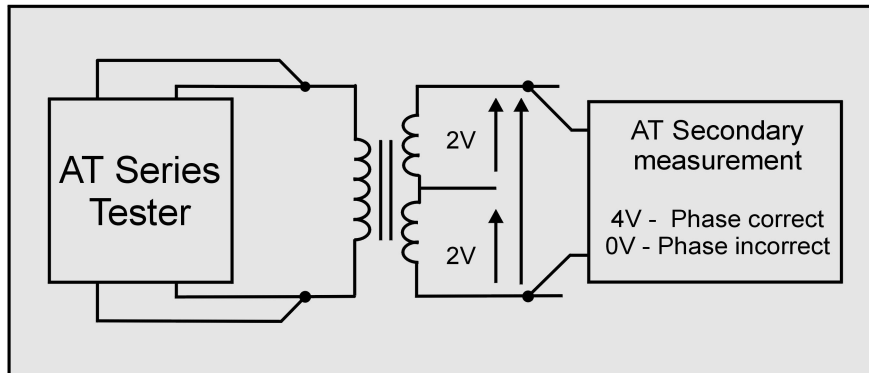

Open circuit voltage is the voltage appearing across a secondary winding when the primary is energized at a specified voltage and frequency, with the secondary at no load.

The voltage is dependent not only on the turns ratio of the transformer, but also on the voltage drop in the primary winding due to magnetizing current.

WHERE USED

Low open circuit voltage measurements utilise the low voltage, high frequency generator of the AT testers to measure the output voltage of transformers over a wide frequency range.

The LVOC test can be used in place of a turns ratio test to set limits in terms of output voltage rather than turns ratio.

A low open circuit voltage test is thus used to confirm the turns ratio between windings and phasing of windings on a transformer.

See also the TR, TRL and VOC tests.

MEASUREMENT CONDITIONS

Open circuit voltage is measured by applying an ac test voltage to a selected winding (usually a primary winding), and measuring the resulting voltage produced on another winding.

The AT Series tester takes measurements using either a normal ac (rms) measurement or a dc (mean)

measurement. Generally, the ac rms is used, but the dc measurement could be used if, for example, the transformer under test is fitted with a rectifying diode.

TEST SPECIFICATION

| Test | Measurement Range | Test Voltage | Test Frequency | Basic Accuracy |
|------|---|--------------|----------------|----------------|
| LVOC | 100 μ V to 650V (100 μ V to 5V, ATi) | 1mV to 5V | 20Hz to 3MHz | 0.1% |

TO ORDER

To order the Low Voltage Open Circuit test, ask for LVOC on your order form.

USA Tel: 919 431 0015 Fax: 919 431 0090 Email: sales@voltech.com

Europe Tel: +44 (0)1235 834555 Fax: +44 (0)1235 835016 Email: sales@voltech.co.uk

86-226 Iss4 © 2001 Voltech

<http://www.voltech.com>

Page 21 of 37

AT TEST OPTIONS

IR – INSULATION RESISTANCE TEST OPTION

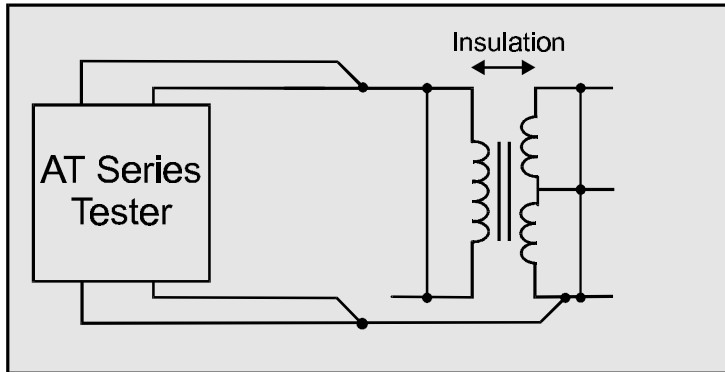

Transformer windings are often insulated from each other and from the core by insulating tape, enamel on the wire or by plastic moulding on the bobbin.

The 'quality' of the insulation can be assessed by applying a DC voltage across the insulation and measuring the resistance. The voltage applied is usually greater than the voltage that the insulation will see in normal use.

WHERE USED

An insulation Resistance check is recommended as good practice for most transformers to check the integrity of the

insulation between separate windings, or between a winding, or between a winding and a screen.

MEASUREMENT CONDITIONS

To measure insulation resistance, the tester applies a dc voltage between two groups of windings with the windings in each group being shorted together. Each group may contain as many windings as you wish.

The voltage and current are measured; dividing the voltage by the current gives the insulation resistance. The voltage should normally be set to just greater than twice the peak working voltage of the winding.

TEST SPECIFICATION

| Test | Measurement Range | Test Voltage | Test Frequency | Basic Accuracy |
|------|--|--------------------------------------|----------------|----------------|
| IR | 1M Ω to 100G Ω (1M Ω to 10G Ω on ATi) | 100V to 7kV (100V to 500V on ATi) | DC | 1.0% |

TO ORDER

To order the Insulation Resistance test, ask for IR on your order form.

USA Tel: 919 431 0015 Fax: 919 431 0090 Email: sales@voltech.com

Europe Tel: +44 (0)1235 834555 Fax: +44 (0)1235 835016 Email: sales@voltech.co.uk

86-226 Iss4 © 2001 Voltech

<http://www.voltech.com>

Page 22 of 37

AT TEST OPTIONS

AT3600
ONLY

HPDC & HPAC – HI-POT AC AND DC TEST OPTIONS

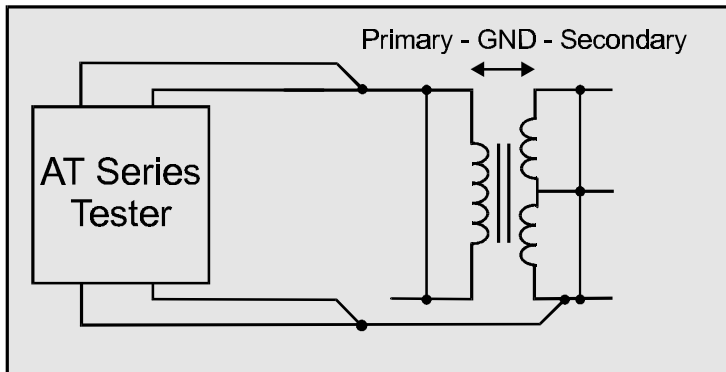

Transformers may be used to provide isolation between dangerous line input voltages and safe low voltage outputs. The transformers may be separate line frequency transformers or power or control transformers inside power supplies and similar equipment.

To ensure user safety throughout the life of the transformer the critical insulation must be tested at a very high voltage. No breakdown may occur.

WHERE USED

A Hi-POT (High Potential), or 'flash' test is applied to isolating transformers to guarantee the integrity of safety critical insulation in accordance with international standards. Primary to secondary insulation is always tested, primary to core or ground or primary to core + secondaries or core to secondaries may also be specified.

Standards often describe Hi-Pot tests at ac voltages; a dc test at a voltage equivalent to the ac peak may be acceptable.

MEASUREMENT CONDITIONS

The AT3600 applies a voltage between two groups of windings (or core) with the windings in each group being shorted together. Should current flow between the groups of windings which is above the programmed level the

AT3600 will record a Hi-Pot test fail. The AT3600 continuously monitors and trims the Hi-Pot voltage during a test. Hi-Pot ramp-up and dwell times are fully programmable.

TEST SPECIFICATION

| Test | Measurement Range | Test Voltage | Test Frequency | Basic Accuracy |
|------|----------------------|---------------|----------------|----------------|
| HPDC | 1 μ A to 3mA | 100V to 7kV | DC | 3.2% |
| HPAC | 10 μ A to 10mApk | 100V to 5.5kV | 50Hz to 1kHz | 3.0% |

TO ORDER

To order the Hi-Pot ac test, ask for HPAC on your order form.
To order the Hi-Pot dc test, ask for HPDC on your order form.

These options are available for the AT3600 only.

USA Tel: 919 431 0015 Fax: 919 431 0090 Email: sales@voltech.com

Europe Tel: +44 (0)1235 834555 Fax: +44 (0)1235 835016 Email: sales@voltech.co.uk

86-226 Iss4 © 2001 Voltech

<http://www.voltech.com>

Page 23 of 37

AT TEST OPTIONS

**AT3600
ONLY**

SURG – SURGE STRESS TEST OPTION

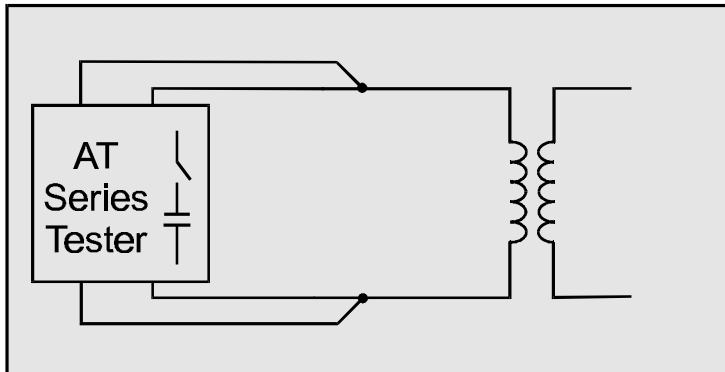

The wire used to wind a transformer may contain defects in its insulation. For example, scratches in the enamel of copper winding wire. This test may be used to highlight insulation defects between adjacent turns in a winding as opposed to insulation defects between windings.

In some cases, the wire insulation defect does not immediately cause a shorted turn, but will leave a weak spot which may eventually fail in use. By applying a higher than normal voltage across the winding, any weakness in wire insulation will be identified at the test stage.

WHERE USED

It is applicable to any transformer, but is particularly suitable for transformers with a large number of turns using very fine wire.

The test voltage is generally applied to the primary of a transformer. All other windings of the transformer are

simultaneously tested because of the normal action of the transformer which applies the same volts per turn to every winding.

MEASUREMENT CONDITIONS

Each SURG test can be programmed to consist of a number of impulses.

For each impulse, the AT3600 will charge an internal capacitor to the high voltage specified. This stored charge will then be suddenly discharged into the winding under test, and the resulting transient voltage will be analysed.

The product from the discharge will be a sinusoidal wave with decaying amplitude. The transformer is characterized by the area under the wave-form, measured in volt-seconds.

Faulty inter turn insulation will dissipate some of the impulse energy and reduce the decay time. The AT3600 will then report a 'Volt-second' measurement which is smaller than that of a perfect transformer.

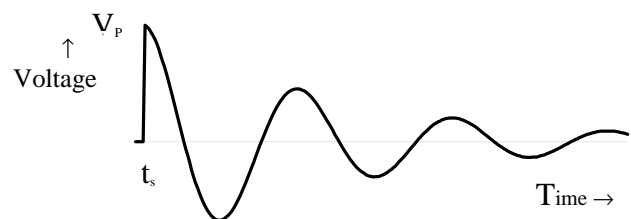

Where t_s = Time of releasing the impulse
 V_P = Peak voltage after switch-on

TEST SPECIFICATION

| Test | Measurement Range | Test Voltage | Impulses Per Test | Basic Accuracy |
|------|-------------------|--------------|-------------------|----------------|
| SURG | 1mV-s to 1kV-s | 100 to 5kV | 1 to 99 | 3% |

TO ORDER

To order the Surge Stress test, ask for SURG on your order form.

This option is available for the AT3600 only.

USA Tel: 919 431 0015 Fax: 919 431 0090 Email: sales@voltech.com

Europe Tel: +44 (0)1235 834555 Fax: +44 (0)1235 835016 Email: sales@voltech.co.uk

86-226 Iss4 © 2001 Voltech

<http://www.voltech.com>

Page 24 of 37

AT TEST OPTIONS

AT3600
ONLY

WATT – WATTAGE TEST OPTION

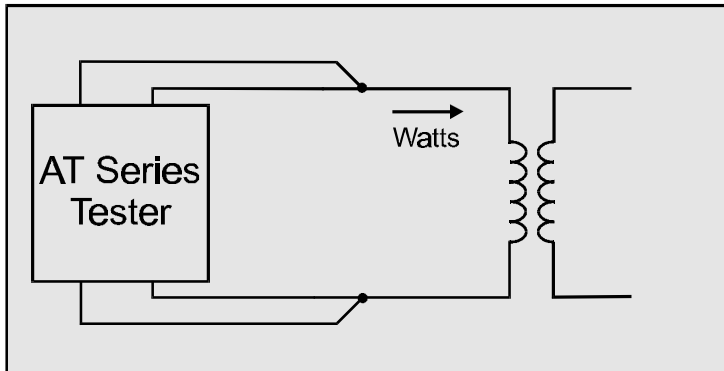

At no load, with the secondaries open circuited, a transformer will still draw current and consume power. The current is typically only a few percent of the normal full-load current, and the I^2R copper loss is thus negligible. The measured power is then the power dissipated by eddy current and hysteresis effects in the core and is known as the core loss. The core loss will vary with the chosen grade of core material and the quality of its assembly, especially where laminates are stacked together.

WHERE USED

The wattage test is used on line frequency power transformers to measure core loss. This can confirm that the transformer has been assembled properly, with the

appropriate number of turns, the right grade of magnetic material for the core, and the correct air gap if required.

MEASUREMENT CONDITIONS

When making a wattage measurement, the normal test signal applied to the primary winding is the full working voltage at the lowest working frequency, for example 230V, 50HZ.

The AT3600 uses an energizing sequence that minimizes any switch-on transient and therefore allows for a quicker measurement. For repeatable results, the AT3600 does not start measurements until the transient has settled.

TEST SPECIFICATION

| Test | Measurement Range | Test Voltage | Test Frequency | Basic Accuracy |
|------|-------------------|--------------|----------------|----------------|
| WATT | 1mW to 40W | 1 to 270V | 20Hz to 1500Hz | 0.3% |

TO ORDER

To order the Wattage test, ask for WATT on your order form.

This option is available for the AT3600 only.

USA Tel: 919 431 0015 Fax: 919 431 0090 Email: sales@voltech.com

Europe Tel: +44 (0)1235 834555 Fax: +44 (0)1235 835016 Email: sales@voltech.co.uk

86-226 Iss4 © 2001 Voltech

<http://www.voltech.com>

Page 25 of 37

AT TEST OPTIONS

AT3600
ONLY

STRW – STRESS WATTS TEST OPTION

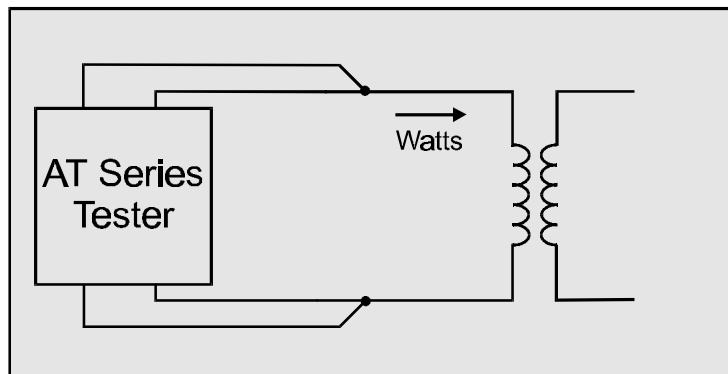

At no load, and with its secondaries open circuited, a transformer will still draw current and consume power as described in the WATT test.

If the voltage and frequency applied to the transformer are changed together and in proportion, Faraday's law shows that the flux density(B) in the core will remain the same.

$$B \propto V / (f \times A \times N)$$

Where N is the number of turns and A is the cross sectional area of the core.

Over a limited range, the core loss (in Watts) should also remain the same as voltage and frequency are changed.

Should the input power increase dramatically, then a winding fault is indicated..

WHERE USED

The stress watts test is used to check for faults in inter-turn insulation within a winding. The test may be used on transformers wound with very fine wire (where the wire

insulation is more susceptible to damage) such as miniature line frequency and some high frequency transformers.

MEASUREMENT CONDITIONS

A stress watts test is often carried out at double the normal operating voltage and frequency. For example, a winding rated at 110V, 60Hz will be tested at 220V, 120Hz. The tester measures the voltage across and the current through the winding. Stress watts is the product of the in phase components of current and voltage.

At this increased voltage, faults in inter-turn insulation may be detected by an increase in the total power consumed. (The fault might not be apparent at the normal operating voltage.)

The tester uses an energizing sequence that minimizes any switch-on transient and therefore allows for a quicker measurement. For repeatable results, the tester does not start measurements until the transient has settled.

It is not necessary to test every winding of a transformer since they are all tested simultaneously through normal transformer action when one test is carried out. Similarly, it is not necessary to apply high voltages to a high voltage winding (E.g. 460V to 230V winding) if a lower voltage winding is available.

TEST SPECIFICATION

| Test | Measurement Range | Test Voltage | Test Frequency | Basic Accuracy |
|------|-------------------|--------------|----------------|----------------|
| STRW | 1mW to 40W | 1 to 270V | 20Hz to 1500Hz | 1% |

TO ORDER

To order the Stress Watts test, ask for STRW on your order form.

This option is available for the AT3600 only.

USA Tel: 919 431 0015 Fax: 919 431 0090 Email: sales@voltech.com

Europe Tel: +44 (0)1235 834555 Fax: +44 (0)1235 835016 Email: sales@voltech.co.uk

86-226 Iss4 © 2001 Voltech

<http://www.voltech.com>

Page 26 of 37

AT TEST OPTIONS

AT3600
ONLY

ILK – LEAKAGE CURRENT TEST OPTION

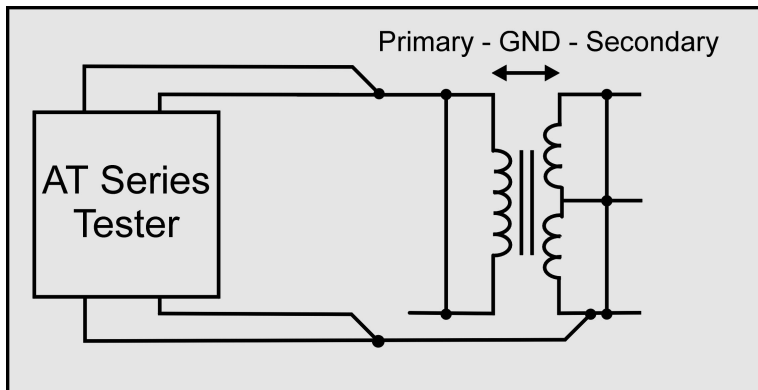

Transformers may be used to provide isolation between dangerous line input voltages and safe low voltage outputs.

When the primary is energised, there exists a 110 or 230V ac common mode voltage from primary to ground. Stray resistance and capacitance then provides a path for some 'leakage' current to flow from the primary side to ground.

This leakage current may affect the proper operation of the complete product or present an electric shock hazard to the user.

WHERE USED

A leakage current test may be performed on any ferrite or iron cored transformer. It is an especially important test for transformers that are to be incorporated into medical equipment where a patient may become the path for leakage current to flow to ground.

The test confirms that the leakage current is below the level set by a safety standard or the transformer designer.

MEASUREMENT CONDITIONS

The AT3600 applies an ac voltage between two groups of windings (or core) with the windings in each group being shorted together. Should current flow between the groups

of windings that is above the programmed level the AT3600 will record a leakage current test fail.

TEST SPECIFICATION

| Test | Measurement Range | Test Voltage | Test Frequency | Basic Accuracy |
|------|-------------------|--------------|----------------|----------------|
| ILK | 1 μ A to 10mA | 1V to 270V | 20Hz to 1500Hz | 0.5% |

TO ORDER

To order the Leakage Current test, ask for ILK on your order form.

This option is available for the AT3600 only.

USA Tel: 919 431 0015 Fax: 919 431 0090 Email: sales@voltech.com

Europe Tel: +44 (0)1235 834555 Fax: +44 (0)1235 835016 Email: sales@voltech.co.uk

86-226 Iss4 © 2001 Voltech

<http://www.voltech.com>

Page 27 of 37

AT TEST OPTIONS

GBAL – GENERAL LONGITUDINAL BALANCE TEST OPTION

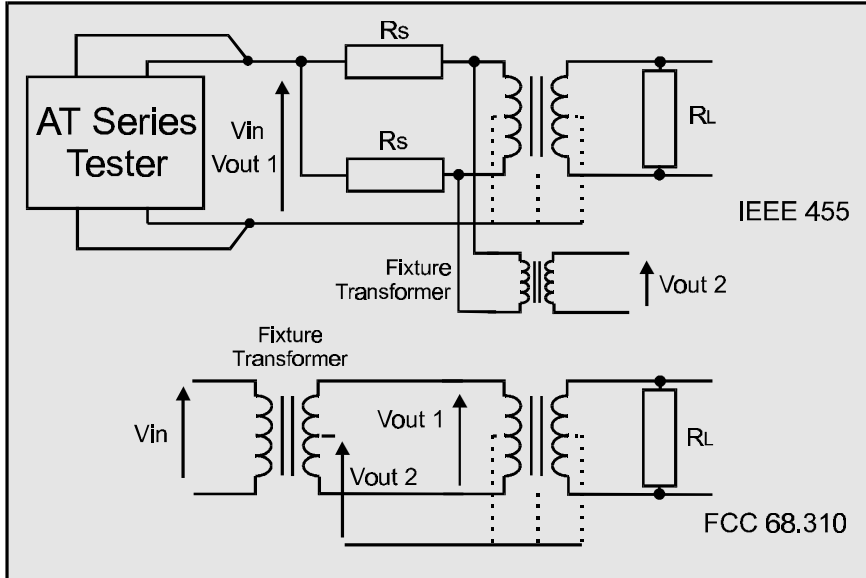

Longitudinal balance is a measure of the common mode rejection ratio (CMRR) of a transformer. That is, the ability of the transformer to reject unwanted noise signals that are common to both input terminals with respect to a common point.

An ideal transformer would have infinite CMRR ($V_{out1} = 0$). In practice differences in symmetry of transformer construction mean that input common mode signals appear as unwanted output voltages.

See also the LBAL test.

WHERE USED

The general longitudinal balance test – as opposed to the standard longitudinal balance test LBAL - is used to confirm the longitudinal balance (or CMRR) of audio and

telecommunications transformers to the standards IEEE455 and FCC 68.310 and wherever similar connection methods are specified.

MEASUREMENT CONDITIONS

The source and load resistors (R_s and R_L) and the measuring transformer are connected to the transformer under test as shown. This may be done automatically using the tester's OUT test.

The voltages V_{out1} and V_{out2} are measured whilst V_{in} is held constant. The ratio of these two voltages reflects the transformer under test's ability to reject common mode voltages.

General Longitudinal balance is calculated as the ratio:

$$GBAL = 20 \log \left| \frac{V_{out2}}{V_{out1}} \right|$$

The tester can automatically scale the result if a scaled measuring transformer is used.

TEST SPECIFICATION

| Test | Measurement Range | Test Voltage | Test Frequency | Basic Accuracy |
|------|-------------------|--------------|----------------|----------------|
| GBAL | 0 dB to 100 dB | 1mV to 5V | 20Hz to 3MHz | 0.5dB |

TO ORDER

To order the General Longitudinal Balance test, ask for GBAL on your order form.

USA Tel: 919 431 0015 Fax: 919 431 0090 Email: sales@voltech.com

Europe Tel: +44 (0)1235 834555 Fax: +44 (0)1235 835016 Email: sales@voltech.co.uk

86-226 Iss4 © 2001 Voltech

<http://www.voltech.com>

Page 28 of 37

AT TEST OPTIONS

LBAL – LONGITUDINAL BALANCE TEST OPTION

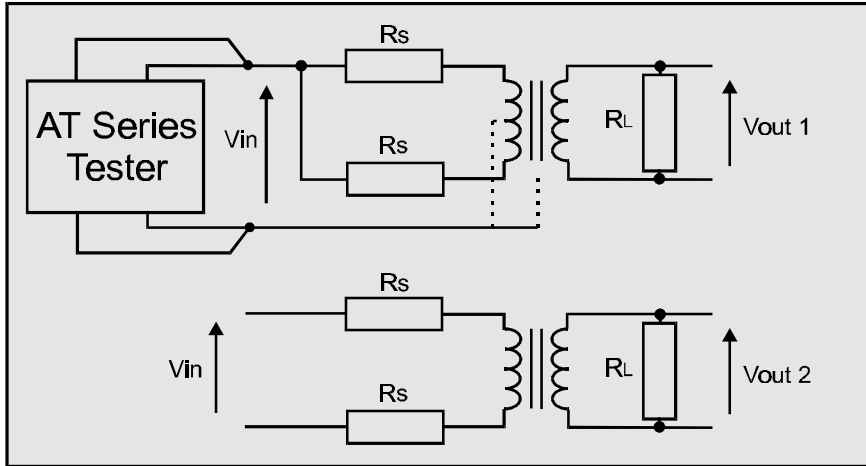

Longitudinal balance is a measure of the common mode rejection ratio (CMRR) of a transformer. That is, the ability of the transformer to reject unwanted noise signals that are common to both input terminals with respect to a common point.

An ideal transformer would have infinite CMRR ($V_{out1} = 0$). In practice differences in symmetry of transformer construction mean that input common mode signals appear as unwanted output voltages.

See also the GBAL test.

WHERE USED

The longitudinal balance test is used to confirm the CMRR of audio and telecommunications transformers that are designed to be connected to a balanced line. The test

ensures that the transformer will reject common mode noise signals as required in use. Faults in the placement of windings or core may be detected using this test.

MEASUREMENT CONDITIONS

The source and load resistors (R_s and R_L) are connected to the transformer - this may be done automatically using the tester's OUT test. Then two measurements are performed using the circuits above which the tester automatically configures. First the test voltage V_{in} is applied as a common mode signal and the output voltage

V_{out1} is recorded, then the same V_{in} is applied as a normal input voltage and the output V_{out2} is recorded. Longitudinal balance is calculated as the ratio:

$$LBAL = 20 \log \left| \frac{V_{out2}}{V_{out1}} \right|$$

TEST SPECIFICATION

| Test | Measurement Range | Test Voltage | Test Frequency | Basic Accuracy |
|------|-------------------|--------------|----------------|----------------|
| LBAL | 0 dB to 100 dB | 1mV to 5V | 20Hz to 3MHz | 0.5dB |

TO ORDER

To order the Longitudinal Balance test, ask for LBAL on your order form.

USA Tel: 919 431 0015 Fax: 919 431 0090 Email: sales@voltech.com

Europe Tel: +44 (0)1235 834555 Fax: +44 (0)1235 835016 Email: sales@voltech.co.uk

86-226 Iss4 © 2001 Voltech

<http://www.voltech.com>

Page 29 of 37

AT TEST OPTIONS

ILOS – INSERTION LOSS TEST OPTION

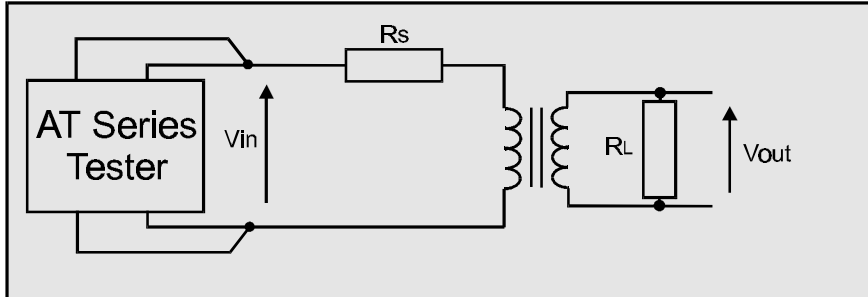

The insertion loss is a measure of the power lost by a transformer relative to the maximum theoretical power that the transformer could transmit to a given load. Core and winding resistance losses mean that some power is always consumed by a transformer, reducing the power available to the load from the theoretical maximum.

WHERE USED

The insertion loss test is used to check the power loss of audio and telecommunications transformers. The test

helps to ensure that the transformer has been assembled properly using the correct core and winding materials.

MEASUREMENT CONDITIONS

The source and load resistors (R_s and R_L) are connected to the transformer under test as shown. This may be done automatically using the tester's OUT test. The tester applies the specified voltage, V_{in} and the voltage V_{out} is measured.

The ratio of actual to theoretical power loss is calculated using the formula:

$$ILOS = 10 \log (V_{in}^2 R_L / 4 V_{out}^2 R_s)$$

TEST SPECIFICATION

| Test | Measurement Range | Test Voltage | Test Frequency | Basic Accuracy |
|------|-------------------|--------------|----------------|----------------|
| ILOS | -100dB to +100dB | 1mV to 5V | 20Hz to 3MHz | 0.5dB |

TO ORDER

To order the Insertion Loss test, ask for ILOS on your order form.

USA Tel: 919 431 0015 Fax: 919 431 0090 Email: sales@voltech.com

Europe Tel: +44 (0)1235 834555 Fax: +44 (0)1235 835016 Email: sales@voltech.co.uk

AT TEST OPTIONS

RESP – FREQUENCY RESPONSE TEST OPTION

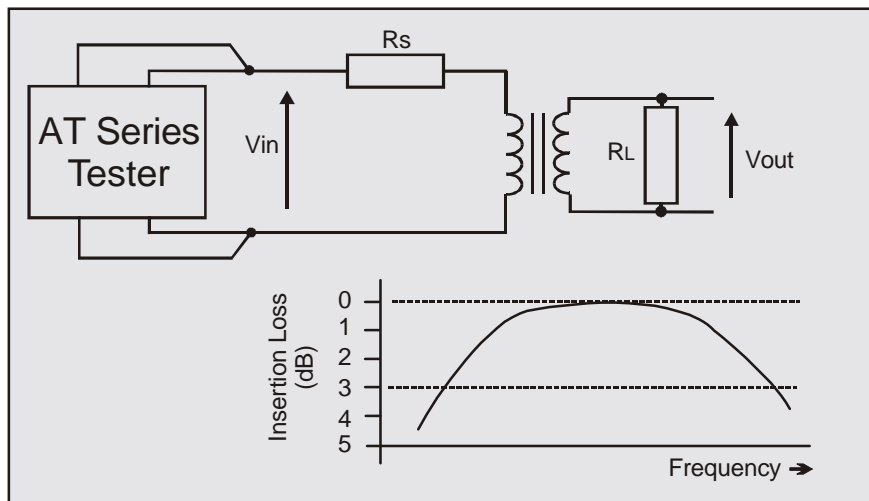

Frequency response is a measure of how the power lost by a transformer (inserted into an impedance matched transmission system) varies with frequency. For an ideal transformer, there would be no power loss. In a real transformer, the power loss increases at low and high frequencies due mainly to the effects of the magnetising and leakage impedances respectively.

WHERE USED

The frequency response test is used to check the power loss against frequency of audio and telecommunications transformers. The test helps to ensure that the transformer has been assembled properly using the correct core and

winding materials and that it meets its published specification.

MEASUREMENT CONDITIONS

The frequency response test consists of up to 20 insertion loss (ILOS) tests repeated at high speed over a range of user defined frequencies.

The source and load resistors (R_s and R_L) are connected to the transformer under test as shown. This may be done automatically using the tester's OUT test.

The first test is made at a reference frequency that is usually near the middle of the band of frequencies of interest. The tester applies the specified voltage V_{in} , and measures the voltage V_{out} . Further measurements of

V_{out} are then made at the chosen frequencies using the same V_{in} . For each frequency, the insertion loss in dB relative to the insertion loss at the reference frequency is calculated.

The result of a RESP test is the single ILOS measurement (in relative dB) that is either closest to the specified limits (if all measurements are inside the limits) or furthest away from the limits (if any measurement is outside the limits).

TEST SPECIFICATION

| Test | Measurement Range | Test Voltage | Test Frequency | Basic Accuracy |
|------|-------------------|--------------|----------------|----------------|
| RESP | -100dB to +100dB | 1mV to 5V | 20Hz to 3MHz | 1.0dB |

TO ORDER

To order the Frequency Response test, ask for RESP on your order form.

USA Tel: 919 431 0015 Fax: 919 431 0090 Email: sales@voltech.com

Europe Tel: +44 (0)1235 834555 Fax: +44 (0)1235 835016 Email: sales@voltech.co.uk

86-226 Iss4 © 2001 Voltech

<http://www.voltech.com>

Page 31 of 37

AT TEST OPTIONS

RLOS – RETURN LOSS TEST OPTION

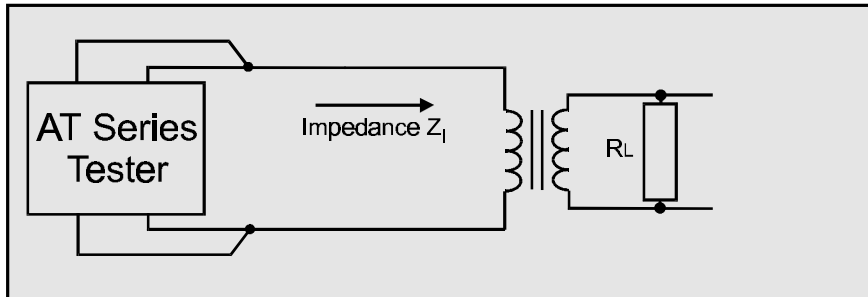

The return loss is a measure of the impedance mismatch between the transformer and a transmission line.

If the impedances are not the same, some signal power is reflected or returned to the transmission line instead of being coupled through the transformer.

WHERE USED

The return loss test is used to check the impedance of audio and telecommunications transformers that are to be used with transmission lines of specified impedance. The

test helps to ensure that the transformer has been assembled properly using the correct core and winding materials.

MEASUREMENT CONDITIONS

The load resistor (RL) is connected to the transformer under test as shown. This may be done automatically using the tester's OUT test.

The tester applies the specified voltage and, using harmonic analysis, measures the combined impedance of the transformer and load resistor.

The return loss is calculated using the formula:

$$RLOS = 20 \log \left(\frac{|Z_R + Z_I|}{|Z_R - Z_I|} \right)$$

Where Z_R is the specified transmission line impedance.

TEST SPECIFICATION

| Test | Measurement Range | Test Voltage | Test Frequency | Basic Accuracy |
|------|-------------------|--------------|----------------|----------------|
| RLOS | -100dB to +100dB | 1mV to 5V | 20Hz to 3MHz | 0.2% |

TO ORDER

To order the Return Loss test, ask for RLOS on your order form.

USA Tel: 919 431 0015 Fax: 919 431 0090 Email: sales@voltech.com

Europe Tel: +44 (0)1235 834555 Fax: +44 (0)1235 835016 Email: sales@voltech.co.uk

AT TEST OPTIONS

Z & ZB – IMPEDANCE TEST OPTIONS

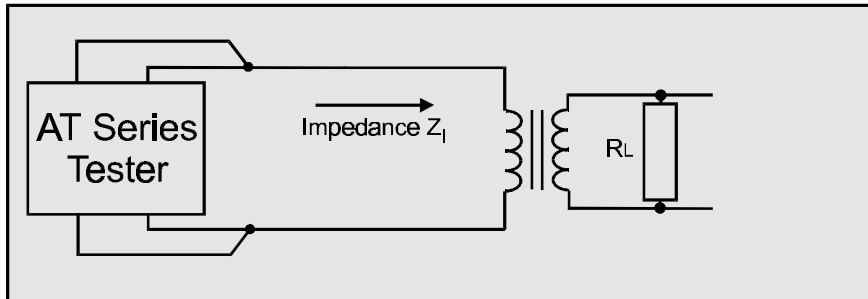

The impedance of a transformer is usually complex, that is it consists of real (resistive) and inductive or capacitive (imaginary) parts. The total impedance at a specified frequency is the vector sum of these parts.

$$Z = \sqrt{R^2 + X^2}$$

Where R and X are the real and imaginary parts of the total impedance.

WHERE USED

The impedance test checks the impedance of audio and telecommunications transformers that are to be used with transmission lines of specified impedance. The test helps

to ensure that the transformer has been assembled properly using the correct core and winding materials.

MEASUREMENT CONDITIONS

The load resistor (RL) is connected to the transformer under test as shown. This may be done automatically using the tester's OUT test.

The tester applies the specified voltage (and bias current for ZB) and, by measuring both the applied voltage and the resulting current, the total impedance is calculated.

TEST SPECIFICATION

| Test | Measurement Range | Test Voltage | Test Frequency | Basic Accuracy |
|------|--------------------|-----------------------|----------------|----------------|
| Z | 1mΩ to 1MΩ | 1mV to 5V | 20Hz to 3MHz | 0.2% |
| ZB | 1mΩ to 1MΩ | 1mV to 5V | 20Hz to 3MHz | 0.2% |
| | ZB dc bias current | 1mA to 400mA (AT3600) | | |
| | | 1mA to 1A (ATi) | | |

TO ORDER

To order the Impedance test, ask for Z on your order form.

To order the Impedance test with bias, ask for ZB on your order form.

USA Tel: 919 431 0015 Fax: 919 431 0090 Email: sales@voltech.com

Europe Tel: +44 (0)1235 834555 Fax: +44 (0)1235 835016 Email: sales@voltech.co.uk

AT TEST OPTIONS

ANGL – IMPEDANCE PHASE ANGLE TEST OPTION

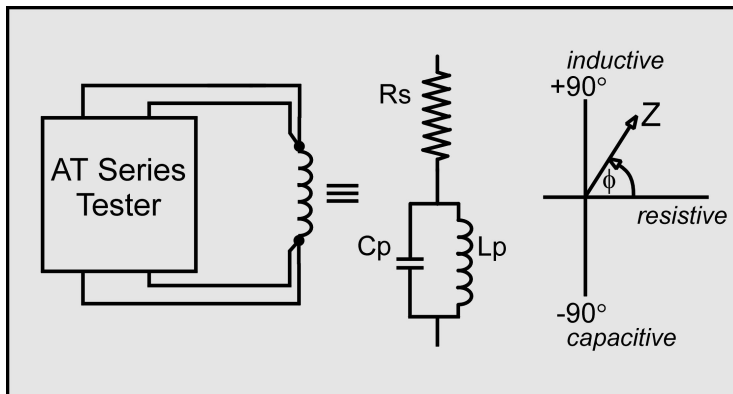

The impedance of a winding is usually complex as it consists of real (resistive) and inductive or capacitive (imaginary) parts. The phase angle ϕ , of the complex impedance at a specified frequency is:

$$\phi = \tan^{-1} (X / R)$$

Where R and X are the real and imaginary parts of the complex impedance.

See also the impedance test, Z, which measures the magnitude of the impedance:

$$Z = \sqrt{(R^2 + X^2)}$$

WHERE USED

An impedance phase angle test may be performed on any ferrite or iron cored winding, but it is an especially important test of audio, telecommunication and other signal components where the angle of the impedance is important.

Measuring the phase angle of the impedance will help to determine that the part has been properly assembled using the correct cores and the right gauge of wire.

MEASUREMENT CONDITIONS

The AT Series tester applies the specified ac voltage to the winding under test. Using harmonic analysis, the phase angle of the impedance is determined from the

measured voltage and the current flowing through the winding.

TEST SPECIFICATION

| Test | Measurement Range | Test Voltage | Test Frequency | Basic Accuracy |
|------|-------------------|--------------|----------------|----------------|
| ANGL | -360° to +360° | 1mV to 5V | 20Hz to 3MHz | 0.05° |

TO ORDER

To order the Impedance Phase Angle test, ask for ANGL on your order form.

USA Tel: 919 431 0015 Fax: 919 431 0090 Email: sales@voltech.com

Europe Tel: +44 (0)1235 834555 Fax: +44 (0)1235 835016 Email: sales@voltech.co.uk

86-226 Iss4 © 2001 Voltech

<http://www.voltech.com>

Page 34 of 37

AT TEST OPTIONS

PHAS – INTERWINDING PHASE ANGLE TEST OPTION

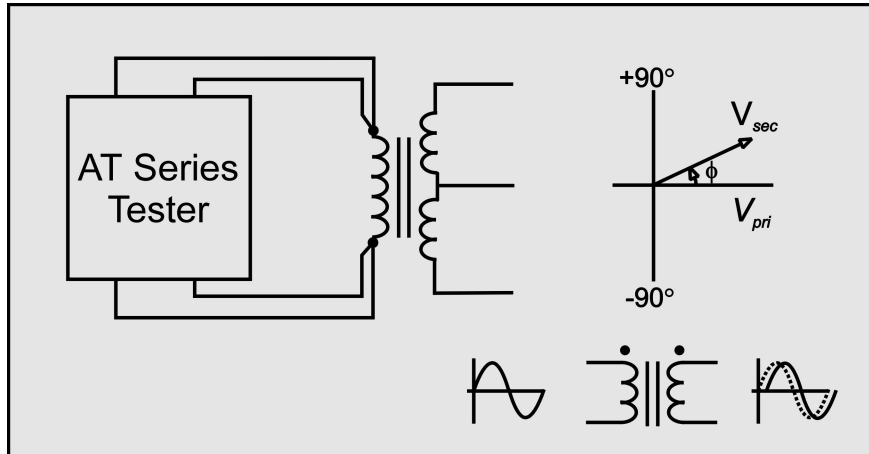

When the ac voltage across one winding is compared to the voltage across another, they may be different in amplitude and phase.

Where the turns ratio or open circuit voltage tests measure the *amplitude* of the voltages, the PHAS test measures the *phase* difference between the two voltage waveforms.

WHERE USED

The interwinding phase angle test is most often used on measuring and other signal transformers where the phase displacement of signals is important to the operation of the complete circuit or product.

The test determines the angle, measured in degrees, between the voltage signals across two different windings. This is different to the polarity test incorporated into the TR (Turns Ratio) test which can only determine (+)^{ve} or (-)^{ve} polarity.

MEASUREMENT CONDITIONS

The AT Series tester applies the specified ac voltage to one winding and measures the voltage produced across two windings, one of which may be the energized winding.

The phase angle between the voltages is determined using harmonic analysis.

TEST SPECIFICATION

| Test | Measurement Range | Test Voltage | Test Frequency | Basic Accuracy |
|------|-------------------|--------------|----------------|----------------|
| PHAS | -360° to +360° | 1mV to 5V | 20Hz to 3MHz | 0.05° |

TO ORDER

To order the Interwinding Phase Angle test, ask for PHAS on your order form.

USA Tel: 919 431 0015 Fax: 919 431 0090 Email: sales@voltech.com

Europe Tel: +44 (0)1235 834555 Fax: +44 (0)1235 835016 Email: sales@voltech.co.uk

86-226 Iss4 © 2001 Voltech

<http://www.voltech.com>

Page 35 of 37

AT TEST OPTIONS

TRIM – TRIMMING ADJUSTMENT TEST OPTION

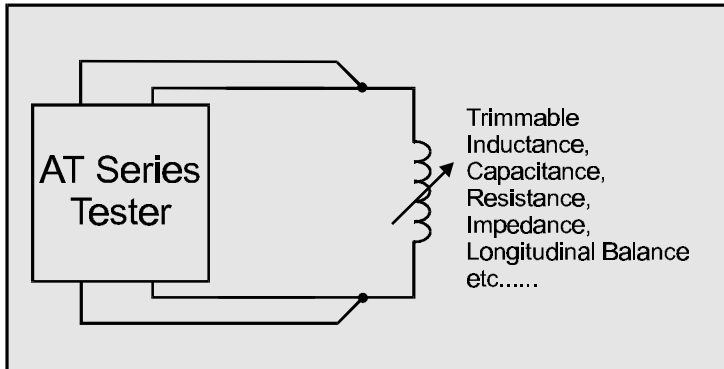

In critical applications, or where the best transformer performance is desired, it may be necessary to trim a particular component parameter to be within desired limits.

For example, small inductors may have a section of the core ferrite that can be screwed in or out, to trim inductance or the quality factor, Q.

WHERE USED

The TRIM test is used on signal, audio and telecommunications transformers and other components where a means of physically adjusting a parameter is

provided. For example, the Q factor of a coil may be tuned to within specified limits by adjusting a trimmable core.

MEASUREMENT CONDITIONS

A TRIM test may be used after any low voltage test on the tester. If the desired parameter is outside the limits specified by that previous test, the tester halts and provides a live display indicating which way (+)ve or (-)ve the operator should adjust the part.

Once trimming is complete and successful the tester can continue with the rest of the tests in the sequence.

Tests that may be TRIMmed include:

R, RLS, RLP, LS, LP, LSP, LSB, Q, D, C, TR, LL, LLO, TR, L2, C2, GBAL, LBAL, ILOS, RLOS, Z and ZB.

TEST SPECIFICATION

| Test | Specification |
|------|-----------------------------------|
| TRIM | As the test result being trimmed. |

TO ORDER

To order the Trimming Adjustment test, ask for TRIM on your order form.

USA Tel: 919 431 0015 Fax: 919 431 0090 Email: sales@voltech.com

Europe Tel: +44 (0)1235 834555 Fax: +44 (0)1235 835016 Email: sales@voltech.co.uk

86-226 Iss4 © 2001 Voltech

<http://www.voltech.com>

Page 36 of 37

AT TEST OPTIONS

OUT – OUTPUT TO USER PORT TEST OPTION

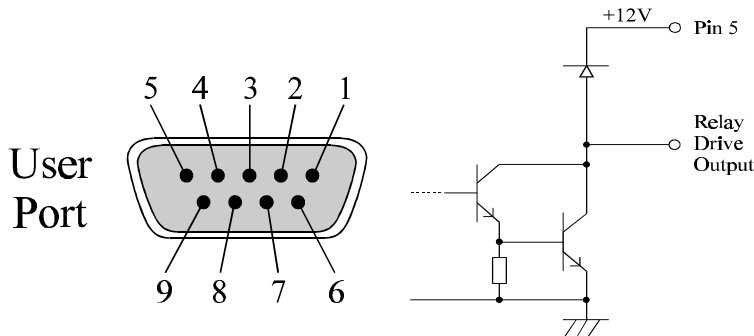

The AT Series testers normally make all the necessary connections for testing automatically using a matrix of internal relays.

When, for example, an external component such as a resistor is required for testing, then during the test sequence the resistor may be switched into or out of the test circuit using an OUT test. A +12V dc power supply ensures that everything necessary to drive an external 12V dc relay is available.

| PIN | SIGNAL NAME | PIN | SIGNAL NAME |
|-----|------------------------|-------|------------------------|
| 1 | o/p USER RELAY DRIVE 0 | 6 | o/p USER RELAY DRIVE 1 |
| 2 | o/p USER RELAY DRIVE 2 | 7 | o/p USER RELAY DRIVE 3 |
| 3 | o/p USER RELAY DRIVE 4 | 8 | o/p USER RELAY DRIVE 5 |
| 5 | o/p +12V | 4 & 9 | i/p DO NOT USE |

WHERE USED

The OUT test is used to switch external relays at any point in a test sequence. The user relays may in turn be used to switch in external components such as impedance matching resistors (important for audio and telecommunications transformers) or to connect windings in series for subsequent testing. For maximum user convenience, the drive signals are present on the User

Port connector situated to the rear of the top of the tester, close to the test fixture.

See also the tests for audio and telecommunications transformers, LBAL, GBAL, ILOS, RLOS and Z.

Most types of power and many signal transformers will be tested using the tester's internal relay matrix to perform switching, and an OUT test is not required for these.

MEASUREMENT CONDITIONS

The OUT 'test' is programmed into a test sequence like any other test. The OUT test programmes any of the six available relay drives in any pattern desired. The drives stay in the programmed state until another OUT test is performed or a new part is tested.

The relay drives controlled by the OUT test are designed for switching external user supplied relays only and should not be connected directly to the tester's test nodes.

TEST SPECIFICATION

| Test | Maximum Current per Drive | DC Supply |
|------|---|--------------|
| OUT | 80mA (Minimum 150Ω relay coil resistance) | +12V ±5%, 1A |

TO ORDER

To order the OUT test, ask for OUT on your order form. **KUST Messgeräte GmbH**

Friedenstraße 26 • D-35578 Wetzlar • Telefon: +49 (0) 6441 4471223

Telefax: +49 (0) 6441 4471225 • E-Mail: info@kust.de • www.kust-messgeraete.eu

USA Tel: 919 431 0015 Fax: 919 431 0090 Email: sales@voltech.com

Europe Tel: +44 (0)1235 834555 Fax: +44 (0)1235 835016 Email: sales@voltech.co.uk